



BSI Standards Publication

Evaluation of a.c. corrosion likelihood of buried pipelines applicable to cathodically protected pipelines

National foreword

This British Standard is the UK implementation of EN 15280:2013. It supersedes DD CEN/TS 15280:2006 which is withdrawn.

The UK participation in its preparation was entrusted to Technical Committee GEL/603, Cathodic protection.

A list of organizations represented on this committee can be obtained on request to its secretary.

This publication does not purport to include all the necessary provisions of a contract. Users are responsible for its correct application.

© The British Standards Institution 2013. Published by BSI Standards Limited 2013

ISBN 978 0 580 75941 3

ICS 23.040.99; 77.060

Compliance with a British Standard cannot confer immunity from legal obligations.

This British Standard was published under the authority of the Standards Policy and Strategy Committee on 30 September 2013.

Amendments issued since publication

Date	Text affected
------	---------------

EUROPEAN STANDARD

EN 15280

NORME EUROPÉENNE

EUROPÄISCHE NORM

August 2013

ICS 23.040.99; 77.060

Supersedes CEN/TS 15280:2006

English Version

Evaluation of a.c. corrosion likelihood of buried pipelines applicable to cathodically protected pipelines

Évaluation du risque de corrosion occasionnée par les
courants alternatifs des canalisations enterrées protégées
cathodiquement

Beurteilung der Korrosionswahrscheinlichkeit durch
Wechselstrom an erdverlegten Rohrleitungen anwendbar
für kathodisch geschützte Rohrleitungen

This European Standard was approved by CEN on 5 July 2013.

CEN members are bound to comply with the CEN/CENELEC Internal Regulations which stipulate the conditions for giving this European Standard the status of a national standard without any alteration. Up-to-date lists and bibliographical references concerning such national standards may be obtained on application to the CEN-CENELEC Management Centre or to any CEN member.

This European Standard exists in three official versions (English, French, German). A version in any other language made by translation under the responsibility of a CEN member into its own language and notified to the CEN-CENELEC Management Centre has the same status as the official versions.

CEN members are the national standards bodies of Austria, Belgium, Bulgaria, Croatia, Cyprus, Czech Republic, Denmark, Estonia, Finland, Former Yugoslav Republic of Macedonia, France, Germany, Greece, Hungary, Iceland, Ireland, Italy, Latvia, Lithuania, Luxembourg, Malta, Netherlands, Norway, Poland, Portugal, Romania, Slovakia, Slovenia, Spain, Sweden, Switzerland, Turkey and United Kingdom.



EUROPEAN COMMITTEE FOR STANDARDIZATION
COMITÉ EUROPÉEN DE NORMALISATION
EUROPÄISCHES KOMITEE FÜR NORMUNG

Management Centre: Avenue Marnix 17, B-1000 Brussels

Contents

Page

Foreword.....	4
1 Scope	5
2 Normative references	5
3 Terms and definitions	5
4 Cathodic protection personnel competence	8
5 Assessment of the a.c. influence	9
5.1 General.....	9
5.2 Assessment of the level of interference.....	9
6 Evaluation of the likelihood of a.c. corrosion.....	10
6.1 Prerequisite	10
6.1.1 General.....	10
6.1.2 A.c. voltage on the structure	10
6.2 A.c. and d.c. current density.....	11
6.2.1 General.....	11
6.2.2 A.c. current density	11
6.2.3 High cathodic d.c. current density.....	11
6.2.4 Low cathodic d.c. current density.....	11
6.2.5 Current ratio " $I_{a.c.}/I_{d.c.}$ "	12
6.2.6 Soil resistivity.....	12
6.3 Corrosion rate	12
6.4 Pipeline coatings	12
6.5 Evaluation of the metal loss	12
7 Acceptable interference levels	12
8 Measurement techniques.....	13
8.1 Measurements.....	13
8.1.1 General.....	13
8.1.2 Selection of test sites	13
8.1.3 Selection of measurement parameter	14
8.1.4 Sampling rate for the recording of interference levels.....	14
8.1.5 Accuracy of measuring equipment.....	14
8.1.6 Installation of coupons or probes to calculate current densities.....	14
8.2 D.c. potential measurements.....	14
8.3 A.c. voltage measurements	15
8.4 Measurements on coupons and probes.....	15
8.4.1 Installation of coupons or probes.....	15
8.4.2 Current measurements	15
8.4.3 Corrosion rate measurements.....	16
8.5 Pipeline metal loss techniques	17
9 Mitigation measures	17
9.1 General.....	17
9.2 Construction measures.....	17
9.2.1 Modification of bedding material	17
9.2.2 Installation of isolating joints	17
9.2.3 Installation of mitigation wires	17
9.2.4 Optimisation of pipeline and/or powerline route.....	18
9.2.5 Power line or pipeline construction.....	18
9.3 Operation measures	18
9.3.1 Earthing	18
9.3.2 Adjustment of cathodic protection level	19

9.3.3	Repair of coating defects	19
10	Commissioning.....	19
10.1	Commissioning.....	19
10.2	Preliminary checking	20
10.2.1	General	20
10.2.2	Start up	20
10.2.3	Verification of effectiveness.....	21
10.2.4	Installation and commissioning documents	21
11	Monitoring and maintenance	21
Annex A	(informative) Simplified description of the a.c. corrosion phenomenon	23
A.1	Cathodically protected pipeline	23
A.2	Cathodically protected pipeline with a.c. voltage	23
A.2.1	Description of the phenomena.....	23
A.2.2	Reduction of the a.c. corrosion rate.....	24
Annex B	(informative) Coupons and probes	25
B.1	Use and sizes of coupons and probes	25
B.1.1	Use of coupons or probes	25
B.1.2	Sizes of coupons or probes	25
B.2	Installation of buried coupons and probes.....	25
B.2.1	General	25
B.2.2	Before installing the coupon or probe	25
B.2.3	Installation of the buried coupon or probe	26
B.3	ER probes principles.....	27
B.3.1	Assessment of the corrosion using the electrical resistance (ER) probe technique	27
B.3.2	ER probe application in the field	29
B.4	Perforation probes	29
Annex C	(informative) Coulometric oxidation	31
Annex D	(informative) Influence of soil characteristics on the a.c. corrosion process	32
D.1	Influence of electrical parameters	32
D.2	Influence of the electrochemical process.....	32
D.3	Influence of alkaline ions and cations.....	32
Annex E	(informative) Other criteria that have been used in the presence of a.c. influence	33
E.1	General	33
E.2	ON-potential approach.....	33
E.2.1	General	33
E.2.2	More negative (Eon) cathodic protection level	33
E.2.3	Less negative (Eon) cathodic protection level	33
E.2.4	Criteria	34
Annex F	(informative) Parameters to take into account to choose a d.c. decoupling device.....	36
F.1	General aspects to be taken into account	36
F.2	Electrical parameters	36
Annex G	(informative) Method to determine the reference electrode location to remote earth	37
Bibliography	38

Foreword

This document (EN 15280:2013) has been prepared by Technical Committee CEN/TC 219 "Cathodic protection", the secretariat of which is held by BSI.

This European Standard shall be given the status of a national standard, either by publication of an identical text or by endorsement, at the latest by February 2014 and conflicting national standards shall be withdrawn at the latest by February 2014.

Attention is drawn to the possibility that some of the elements of this document may be the subject of patent rights. CEN [and/or CENELEC] shall not be held responsible for identifying any or all such patent rights.

This document supersedes CEN/TS 15280:2006.

With this document, CEN/TS 15280:2006 is converted into a European Standard.

The main modification concerns the criteria assumed in the presence of a.c. interference on a pipeline. While CEN/TS 15280:2006 represented a collection of various experiences in the field of a.c. corrosion, this European Standard has incorporated these criteria and thresholds together with experience gained from the most recent data. Various European countries have a different approach to the prevention of a.c. corrosion depending primarily on the d.c. interference situation. These different approaches are taken into account in two different ways:

- either in the presence of "low" ON-potentials (less negative than -1,2 V CSE), which allows a certain level of a.c. voltage (up to 15 V),
- or in the presence of "high" ON-potentials (more negative than -1,2 V CSE ; with d.c. stray current interference on the pipeline for instance) which requires the reduction of the a.c. voltage towards the lowest possible levels.

This European Standard gives also some parameters to consider when evaluating the a.c. corrosion likelihood, as well as detailed measurement techniques, mitigation measures and measurements to carry out for commissioning of any a.c corrosion mitigation system. Note that Annex E proposes other parameters and thresholds that require further validation based on practical experiences.

According to the CEN/CENELEC Internal Regulations, the national standards organisations of the following countries are bound to implement this European Standard: Austria, Belgium, Bulgaria, Croatia, Cyprus, Czech Republic, Denmark, Estonia, Finland, Former Yugoslav Republic of Macedonia, France, Germany, Greece, Hungary, Iceland, Ireland, Italy, Latvia, Lithuania, Luxembourg, Malta, Netherlands, Norway, Poland, Portugal, Romania, Slovakia, Slovenia, Spain, Sweden, Switzerland, Turkey and the United Kingdom.

1 Scope

This European Standard is applicable to buried cathodically protected metallic structures that are influenced by a.c. traction systems and/or a.c. power lines.

In this document, a buried pipeline (or structure) is a buried or immersed pipeline (or structure), as defined in EN 12954.

In the presence of a.c. interference, the protection criteria given in EN 12954:2001, Table 1, are not sufficient to demonstrate that the steel is being protected against corrosion.

This European Standard provides limits, measurement procedures, mitigation measures and information to deal with long term a.c. interference for a.c. voltages at frequencies between 16,7 Hz and 60 Hz and the evaluation of a.c. corrosion likelihood.

This European Standard deals with the possibility of a.c. corrosion of metallic pipelines due to a.c. interferences caused by inductive, conductive or capacitive coupling with a.c. power systems and the maximum tolerable limits of these interference effects. It takes into account the fact that this is a long-term effect, which occurs during normal operating conditions of the a.c. power system.

This European Standard does not cover the safety issues associated with a.c. voltages on pipelines. These are covered in national standards and regulations (see EN 50443).

2 Normative references

The following documents, in whole or in part, are normatively referenced in this document and are indispensable for its application. For dated references, only the edition cited applies. For undated references, the latest edition of the referenced document (including any amendments) applies.

EN 12954:2001, *Cathodic protection of buried or immersed metallic structures — General principles and application for pipelines*

EN 13509:2003, *Cathodic protection measurement techniques*

EN 50443, *Effects of electromagnetic interference on pipelines caused by high voltage a.c. electric traction systems and/or high voltage a.c. power supply systems*

EN 61010-1, *Safety requirements for electrical equipment for measurement, control and laboratory use — Part 1: General requirements (IEC 61010-1)*

3 Terms and definitions

For the purposes of this document, the following terms and definitions apply.

3.1

a.c. electric traction system

a.c. railway electrical distribution network used to provide energy for rolling stock

Note 1 to entry: The system can comprise:

- contact line systems;
- return circuit of electric railway systems;
- running rails of non-electric railway systems, which are in the vicinity of, or conductively connected to, the running rails of an electric railway system.

3.2
a.c. power supply system
a.c. electrical system devoted to electrical energy transmission and including overhead lines, cables, substations and all apparatus associated with them

3.3
a.c. power system
a.c. electric traction system or a.c. power supply system

Note 1 to entry: Where it is necessary to differentiate, each interfering system is clearly indicated with its proper term.

3.4
copper/copper sulphate reference electrode (CSE)
reference electrode consisting of copper in a saturated solution of copper sulphate

3.5
a.c. voltage
voltage measured to earth between a metallic structure and a reference electrode.

3.6
interfering system
general expression encompassing an interfering high voltage a.c. electric traction system and/or high voltage a.c. power supply system

3.7
interfered system
system on which the interference effects appear

Note 1 to entry: In this European Standard, it is the pipeline system.

3.8
pipeline system
system of pipe network with all associated equipment and stations

Note 1 to entry: In this European Standard, pipeline system refers only to metallic pipeline system.

Note 2 to entry: The associated equipment is the equipment electrically connected to the pipeline.

3.9
earth
conductive mass of the earth, whose electric potential at any point is conventionally taken as equal to zero

[SOURCE: IEC 60050 826-04-01]

3.10
operating condition
fault free operation of any system

Note 1 to entry: Transients are not to be considered as an operating condition.

3.11
fault condition
non intended condition caused by short-circuit to earth, the fault duration being the normal clearing time of the protection devices and switches

Note 1 to entry: The short circuit is an unintentional connection of an energised conductor to earth or to any metallic part in contact with earth.

3.12

conductive coupling

coupling which occurs when a proportion of the current belonging to the interfering system returns to the system earth via the interfered system or when the voltage to the reference earth of the ground in the vicinity of the influenced object rises because of a fault in the interfering system, and the results of which are conductive voltages and currents

3.13

inductive coupling

phenomenon whereby the magnetic field produced by a current carrying circuit influences another circuit; the coupling being quantified by the mutual impedance of the two circuits, and the results of which are induced voltages and hence currents that depend for example on the distances, length, inducing current, circuit arrangement and frequency

3.14

capacitive coupling

phenomenon whereby the electric field produced by an energised conductor influences another conductor, the coupling being quantified by the capacitance between the conductors and the capacitances between each conductor and earth, and the results of which are interference voltages into conductive parts or conductors insulated from earth, these voltages depend for example on the voltage of the influencing system, distances and circuit arrangement

3.15

interference

phenomenon resulting from conductive, capacitive, inductive coupling between systems, and which can cause malfunction, dangerous voltages, damage, etc.

3.16

disturbance

malfunction of an equipment losing its capability of working properly for the duration of the interference

Note 1 to entry: When the interference disappears, the interfered system starts again working properly without any external intervention.

3.17

damage

permanent reduction in the quality of service, which can be suffered by the interfered system

EXAMPLE coating perforation, pipe pitting, pipe perforation, permanent malfunction of the equipment connected to the pipes, etc.

Note 1 to entry: A reduction in the quality of service could also be the complete cancellation of service.

3.18

danger

state of the influenced system which is able to produce a threat to human life

3.19

interference situation

maximum distance between the pipeline system and a.c. power system for which an interference is considered

3.20

interference voltage

voltage caused on the interfered system by the conductive, inductive and capacitive coupling with the nearby interfering system between a given point and the earth or across an insulating joint

3.21

IR drop

voltage, due to any current, developed in an electrolyte such as the soil, between the reference electrode and the metal of the structure, in accordance with Ohm's Law

3.22

IR free potential ($E_{IR\ free}$)

structure to electrolyte potential measured without the voltage error caused by the IR drop due to the protection current or any other current

3.23

OFF-potential (E_{OFF})

structure to electrolyte potential measured immediately after synchronous interruption of all sources of applied cathodic protection current

3.24

ON-potential (E_{ON})

structure to electrolyte potential measured with the cathodic protection current flowing

3.25

spread resistance

ohmic resistance through a coating defect to earth or from the exposed metallic surface of a coupon to earth

Note 1 to entry: This is the resistance which controls the d.c. or a.c. current through a coating defect or an exposed metallic surface of a coupon for a given d.c. or a.c. voltage.

3.26

coupon

representative metal sample with known dimensions

Note 1 to entry: A coupon may be electrically connected to the pipeline.

Note 2 to entry: Examples of coupons are given in Annex B.

3.27

probes

device incorporating a coupon that provides measurements of key parameters to assess the corrosion risk

Note 1 to entry: Examples of probes are given in Annex B.

4 Cathodic protection personnel competence

Personnel who undertake the design, supervision of installation, commissioning, supervision of operation, measurements, monitoring and supervision of maintenance of cathodic protection systems shall have the appropriate level of competence for the tasks undertaken.

EN 15257 constitutes suitable methods of assessing competence of cathodic protection personnel, which may be utilised.

Competence of cathodic protection personnel to the appropriate level for the tasks undertaken should be demonstrated by certification in accordance with qualification procedures such as EN 15257 or any other equivalent scheme.

5 Assessment of the a.c. influence

5.1 General

This European Standard is applicable to all metallic pipelines and all high voltage a.c. traction systems and high voltage a.c. power supply systems and all major modifications that can significantly change the a.c. interference effect.

The effects considered within EN 50443 are the following:

- a) danger to people who come in direct contact or contact through conductive parts with the metallic pipeline or the connected equipment;
- b) damage of the pipeline or to the connected equipment;
- c) disturbance of electrical/electronic equipment connected to the pipeline.

Electrical/electronic systems installed on a pipeline network shall be chosen such that they will neither become dangerous, nor interfere with normal operating conditions, because of short term voltages and currents, which appear during short circuits on the a.c. power system.

Long term a.c. interference on a buried pipeline can cause corrosion due to an exchange of a.c. current between the exposed metal of the pipeline and the surrounding electrolyte.

This exchange of current depends on an a.c. voltage whose amplitude is related to various parameters such as:

- the configuration of a.c. power line phase conductors;
- the presence and the configuration of the earthing conductor;
- the distance between the a.c. power line / traction system and the pipeline;
- the current flowing in the a.c. power line / traction system phase conductors;
- the average coating resistance of the pipeline;
- the thickness of the coating;
- the soil resistivity;
- the presence of earthing systems;
- the voltage of the a.c. railway system or the a.c. power line system.

5.2 Assessment of the level of interference

Calculations can be carried out according to EN 50443 by mathematical modelling to determine the earthing requirements necessary to maintain touch voltages within acceptable safe levels. Their results can also be used to determine voltages necessary to reduce the a.c. corrosion likelihood.

During the design phase of new influencing systems (electricity power line or railway line) or a new influenced system (pipelines), an estimation of the level of a.c. voltage on the pipeline should be calculated. Calculations can be carried out by mathematical modelling to determine the level of voltage produced on the pipeline. In the case of existing structures, field measurements can also be used as an option to calculation.

According to the results of calculations or field measurements, relevant mitigation measures should be installed on the influencing systems and/or the influenced system to limit the relevant a.c. voltage to reduce the a.c. corrosion likelihood (see Clause 7).

Guidance on calculating the a.c. voltage on a structure caused by an a.c. power system was published in CIGRE's Technical Brochure No. 95 in 1995 [1]. The algorithm determines the worst case conditions for the input parameters used for the calculation.

Due to inconsistent load demands on a.c. power systems, the magnitude of operating currents in power lines varies. The fluctuations depend on daily and seasonal changes. Input data for calculation purposes should be based on the realistic operating conditions or the maximum power load of the influencing system.

NOTE Carrying out calculations with input data based on both approaches (i.e. at realistic operating loads and maximum power load) is a help to estimate the range between both results and to choose the best method of mitigation.

6 Evaluation of the likelihood of a.c. corrosion

6.1 Prerequisite

6.1.1 General

The a.c. voltage on a pipeline is the driving force for the a.c. corrosion processes taking place on the steel surface at coating defects. Among other things, corrosion damage depends on a.c. current density, level of d.c. polarisation, defect geometry, local soil composition and resistivity (Annex D).

There are three different approaches to prevent a.c. corrosion: one to limit the a.c. current flowing through a defect, one to control the cathodic protection level, and the other to ensure that any coating remains defect free. These approaches are not mutually exclusive.

The evaluation of a.c. corrosion likelihood should be performed by evaluation of some or all of the following parameters:

- a.c. voltage on the structure,
- ON-potential,
- IR-free potential,
- a.c. current density,
- d.c. current density,
- a.c./d.c. current density ratio,
- soil resistivity,
- corrosion rate.

Annexes B, C and E provide further information.

6.1.2 A.c. voltage on the structure

The acceptable a.c. voltage thresholds (see Clause 7 and Annex E) depend on the chosen strategy to prevent a.c. corrosion. Hence, a given interference situation on the pipeline can influence the decision regarding the applicable strategy.

6.2 A.c. and d.c. current density

6.2.1 General

The a.c. and d.c. current density on a coating defect controls both the cathodic protection level and a.c. corrosion process. Therefore it is a more reliable parameter for the evaluation of the a.c. corrosion likelihood than the ON-potential or the a.c. voltage. However, in contrast to the voltages present on the pipeline, the current density cannot be readily determined. In principle the current density can be calculated from the spread resistance and the geometry of the coating defect and the a.c. voltage. This calculation is generally not possible, since the geometry of the coating fault and its surface area are not always known. Moreover, the application of cathodic protection can significantly change the spread resistance and therefore the current density at a given voltage.

The current density can only be estimated by means of coupons or probes. When evaluating the a.c. corrosion likelihood by means of a coupon or probe, it is important to consider the limitations of this technique. The calculation of the current density based upon the metallic coupon or probe surface area and on the current measured on a coupon or probe the current is averaged over the entire coupon or probe surface. However, the current distribution on the coupon or probe can vary depending on its geometry. Typically, current densities at the edges of the coupon or probe are larger than the current averaged over the entire surface. Moreover, the often observed formation of chalk layers can decrease the effective coupon or probe surface area. Again, this effect results in an under estimation of the current density.

6.2.2 A.c. current density

The a.c. current density results in anodic and cathodic charge transfer. A detailed explanation of the charge transfer process is given in Annex A. This current can be consumed in charging of the double layer capacitance at the steel surface, in the oxidation of hydrogen (resulting in a decreasing pH), in the oxidation of corrosion products and the oxidation of the metal. The oxidation of the metal results in corrosion. Generally, an increasing a.c. current density results in a larger amount of metal oxidation and higher corrosion rates. However, the anodic current is not the only current that can affect the corrosion process. Cathodic current can reduce oxide layers formed and increase the pH on the metal surface.

High a.c. current densities do not necessarily cause a.c. corrosion if the charge passed through the metal surface can be consumed in reactions other than metal oxidation and oxide film reduction. This is the case in the presence of low cathodic d.c. current densities. As a consequence, the judgment of the a.c. corrosion likelihood based on the a.c. current density requires the additional consideration of the cathodic d.c. current density.

Nevertheless, there is an empirically determined lower limit for the a.c. current density below which the probability for a.c. corrosion is extremely low (see Clause 7).

6.2.3 High cathodic d.c. current density

A high d.c. current density results in more negative cathodic protection levels and the formation of a high pH at the pipeline surface. However, the formation of a high pH-value, the decrease of the spread resistance, and the increased reduction of surface oxide films can result in an acceleration of the corrosion rate under simultaneous a.c. interference. Nevertheless, a sufficiently high d.c. current density can prevent any anodic metal oxidation and therefore the occurrence of a.c. corrosion.

Annexes A and E give detailed explanations about this process.

6.2.4 Low cathodic d.c. current density

A low d.c. current density results in a limited increase of the pH value at the metal surface, does not significantly change the spread resistance, and has less reductive effect on metal oxides on the pipeline surface. Therefore, the a.c. corrosion likelihood significantly decreases with decreasing d.c. current densities. However, low d.c. current densities can result in an insufficient level of cathodic polarisation of the metal surface as stated in EN 12954.

Annexes A and E give detailed explanations about this process.

6.2.5 Current ratio " $I_{a.c.}/I_{d.c.}$ "

High d.c. current densities, depending on the a.c. current density, can result in both high and low a.c. corrosion rates. Hence, the ratio of the two current densities may be used to assess the corrosion likelihood. As long as the ratio is below a certain threshold (see Clause 7 and Annex E), no a.c. corrosion can occur since metal oxidation in the anodic half wave is prevented. The key advantage of using the ratio as an indicator of corrosion likelihood is that the uncertainties regarding the condition of the metal surface (e.g. formation of a chalk layer) are eliminated, since the precise metal surface area is not required for the calculation.

6.2.6 Soil resistivity

The a.c. corrosion process is controlled by the current density on a steel coating defect, which depends on the voltage at the location and the spread resistance. The spread resistance is influenced by the soil resistivity. The following soil resistivity parameters have been determined by experience in terms of a.c. corrosion risk:

- Below 25 $\Omega.m$: very high risk,
- Between 25 and 100 $\Omega.m$: high risk,
- Between 100 and 300 $\Omega.m$: medium risk,
- Above 300 $\Omega.m$: low risk.

For further guidance on the effect of soil composition on a.c. corrosion risk, Annex D gives more detailed information.

6.3 Corrosion rate

A direct way of evaluating the a.c. corrosion likelihood is by determining the corrosion rate on a probe (see 8.4.3). This allows complex interference situations to be assessed on the basis of the actual measured corrosion rate. The principles of the Electrical Resistance (ER) probe concept are described in Annex B.

6.4 Pipeline coatings

A.c. corrosion can only take place on metal surfaces that are in contact with the surrounding soil. The a.c. current passing through the metal/soil interface results in oxidation of the metal. By providing a holiday-free coating, the risk of a.c. corrosion is greatly reduced.

NOTE This method is limited by the fact it is very difficult in practice to ensure that there are no coating defects on a pipeline.

6.5 Evaluation of the metal loss

Metal loss measurement tools, such as internal inspection, can be used to verify the effectiveness of the applied mitigation measures on new pipelines and to identify if any external metal loss has occurred on existing pipelines without mitigation.

NOTE The resolution in terms of width and depth of the In Line Inspection (ILI) tool is a crucial parameter to be considered to detect metal loss (such as a.c. corrosion).

7 Acceptable interference levels

The design, installation and maintenance of the cathodic protection system shall ensure that the levels of a.c. voltage do not cause a.c. corrosion. Since the conditions vary for each situation, a single threshold value cannot be applied.

This is achieved by reducing the a.c. voltage on the pipeline and current densities as below:

- As a first step, the a.c. voltage on the pipeline should be decreased to a target value, which should be 15 V rms or less. This value is measured as an average over a representative period of time (e.g. 24 h).

and

- As a second step, effective a.c. corrosion mitigation can be achieved by complying with criteria defined in EN 12954:2001, Table 1,

and

- maintaining the a.c. current density (rms) over a representative period of time (e.g. 24 h) to be lower than 30 A/m² on a 1 cm² coupon or probe;

or

- maintaining the average cathodic current density over a representative period of time (e.g. 24 h) lower than 1 A/m² on a 1 cm² coupon or probe if a.c. current density (rms) is more than 30 A/m²;

or

- maintaining the ratio between a.c. current density (Ja.c.) and d.c. current density (Jd.c.) less than 5 over a representative period of time (e.g. 24 h).

NOTE Current density ratios between 3 and 5 indicate a small risk of a.c. corrosion. However, in order to reduce the corrosion risk to a minimum value, smaller ratios of current density than 3 would be preferable (see Annex E).

Further information is provided in informative Annex E.

Effective a.c. corrosion mitigation can be also demonstrated by measurement of corrosion rate.

8 Measurement techniques

8.1 Measurements

8.1.1 General

This subclause covers techniques related to the measurements of the parameters identified in Clause 5.

NOTE It is important that personnel are aware of the safety issues relating to measurements on pipelines subjected to interference by a.c. systems (steady state and fault condition).

Only instruments and cables with sufficient isolation level shall be used (see EN 61010-1).

8.1.2 Selection of test sites

A.c. voltage should be measured at test posts during a general assessment and detailed and comprehensive assessment of the effectiveness of the CP (see EN 12954). Additional measurements shall be carried out during a representative period of time (see Clause 7) at sites where the pipeline operator (or the responsible body acting in his place – or on his behalf) suspects that there might be a risk of a.c. corrosion. Such areas should include:

- areas where the soil resistivity is low (e.g. lower than 25 Ω.m),
- areas where casings are filled with substances with low resistivity properties (e.g. bentonite),
- areas with highest a.c. interference levels,

- areas where a.c. corrosion has previously taken place,
- areas where local d.c. polarisation conditions can favour a.c. corrosion such as areas with cathodic d.c. stray current interference or areas where high levels of cathodic protection are present (see 6.2.3),
- areas where internal inspection tools have detected external metal loss.

At a later stage, the test sites can be restricted to particular positions where the initial analysis has indicated a sustained likelihood of a.c. corrosion.

8.1.3 Selection of measurement parameter

The measurements to be carried out should take into account the parameters described in Clause 6, in accordance with Clause 7.

8.1.4 Sampling rate for the recording of interference levels

The measurement sampling rate shall be consistent with the type of interference. High voltage power system interference can typically require a sampling rate in the order of minutes whereas a.c. or d.c. railway interference can require a sampling rate in the order of seconds.

8.1.5 Accuracy of measuring equipment

The instruments used for measuring any voltages (d.c. or a.c.) shall comply with the conditions set out in EN 13509.

The accuracy of the measuring equipment is only one amongst several factors contributing to the uncertainty of the measurement.

8.1.6 Installation of coupons or probes to calculate current densities

In order to calculate current densities (see Clause 7), the use of coupons or probes is necessary. Refer to 8.4.

8.2 D.c. potential measurements

D.c. potential measurements and associated instrumentation is covered in EN 13509.

Guidance on the accuracy of potential measuring equipment is given in EN 13509:2003, Annex H (normative).

When measuring d.c. potentials in conjunction with a.c. interfered pipelines, a number of factors can cause uncertainty in the measurement:

- 1) The Eoff potential measurements on a pipeline are generally dependent on the filter characteristics of the voltmeter and the time after disconnection of the current source before the reading is taken.
- 2) D.c. decoupling devices such as capacitors and diodes may influence d.c. potentials and d.c. potential measurements. The reliability of measurements of Eoff potentials on the structure itself by interruption techniques can be affected by the time constants and discharge characteristics introduced by such devices.
- 3) IR free potential measurements are affected by the induced a.c. voltage.
- 4) In general (regardless of the measurement technique), the IR free potential is shifted to a more positive value and the d.c. current density is increased by the superimposed a.c. voltage. This reflects the effect of the a.c. voltage on the d.c. polarisation.

The above effects are generally more significant factors than the accuracy of the voltmeter itself regarding the uncertainty of the measurement.

Additional interference sources causing IR-drops as well as possible measuring techniques are given in EN 13509:2003, Table 1.

8.3 A.c. voltage measurements

A.c. voltage measurements are used to determine the level of a.c. interference.

For this purpose measurements shall be made using a data logging device programmed to measure the a.c. voltage in sufficiently short enough intervals (see 8.1.4) to capture the steady state long term interference.

A.c. voltage measurements are made with reference to earth. Annex G gives a method to determine the reference electrode location to earth.

A.c. voltage measurement methods are further described in EN 50443, with reference to appropriate standards and guidelines.

8.4 Measurements on coupons and probes

8.4.1 Installation of coupons or probes

Coupons or probes should be installed so that they are representative of the pipeline conditions. The following points should be considered:

- a) The coupon or probe should be installed in the same soil or backfill as the pipeline itself.
- b) The coupon or probe geometry (size, shape, coating thickness, angle between coating and simulated coating defect) influences the spread resistance and should be taken into consideration. The measurements to respect the criteria defined in Clause 7 shall be carried out on a 1-cm² coupon surface area.
- c) The coupon or probe should not cause or receive any electrical interference from adjacent coupons or coating faults on the pipeline unless being part of the purpose of monitoring.
- d) The coupon or probe should have and maintain effective electrical contact with the surrounding soil – unless lack of contact is part of the purpose of monitoring. During the installation process, the soil around the coupon or probe should be compacted to prevent settlement and voids forming around the coupon or probe. These voids could result in loss of full contact between the coupon or probe surface and the surrounding soil.

Coupons or probes can be installed by a number of different methods, such as:

- during construction of the structure under investigation,
- during excavation activities for investigation of the structure,
- by augering (see Annex B).

The installation method selected depends on site access, the type of soil to be excavated, the cost involved, and the availability of an electrical connection to the structure.

8.4.2 Current measurements

Coupon or probe currents (a.c. or d.c.) can be measured by the voltage drop across a series resistor (see Figure 1). For both a.c. and d.c. current measurements the value of the series resistor should be sufficiently low to avoid significant disturbance of the system. For field measurements, this is typically in the range of 10 Ω for a 1 cm² coupon or probe.

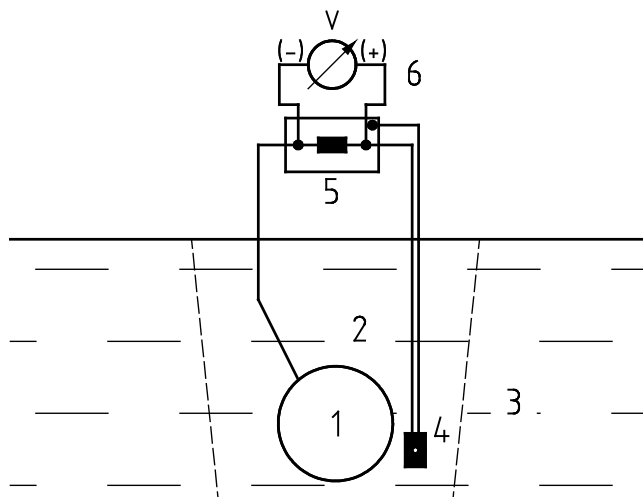

Key

- | | |
|---|-------------------|
| 1 pipe | 2 backfill |
| 3 native soil | 4 coupon or probe |
| 5 series resistor or internal shunt resistor of ammeter | 6 voltmeter |

Figure 1 — Coupon or probe test post with series resistor for current measurements.

One connection between the coupon or probe and the pipe is essential to ensure cathodic protection and the ability to take cathodic protection measurements; a second connection makes measurements easier, more reliable and eliminates the effect of voltage loss in the current carrying conductor.

8.4.3 Corrosion rate measurements

Various types of corrosion rate measurements have been described in the annexes of this European Standard.

Three general types of corrosion rate measurements can be applied:

- weight loss measurements,
- perforation measurements,
- electrical resistance (ER) measurements.

Weight loss measurements require installation of pre-weighed coupons. After some time of operation (months – years) the coupon is excavated. If it is brought to a laboratory for cleaning, inspection and weighing, this should be carried out in accordance with the procedure described in ISO 8407. The primary advantage of the procedure is that the visual inspection provides detailed information of the corrosion topography – maximum as well as average corrosion rate. The primary disadvantage is that the coupon provides no information until it is excavated.

Perforation measurements are made on special perforation probes - see Annex B. A signal is generated when the corrosion process has perforated the wall thickness of the coupon. The primary advantage is that the maximum (localised) corrosion depth is registered without having to excavate the probe. The primary disadvantage is that this information is not available until the coupon is perforated.

Electrical resistance measurements require the installation of electrical resistance probes (ER probes) – see Annex B. Corrosion is detected by the increase of the electrical resistance of the coupon when corrosion progressively decreases the thickness of the coupon. The primary advantage of this technique is that the average corrosion rate can be followed continuously and used to optimise cathodic protection levels. The

primary disadvantage is that localised corrosion rate is detected with less accuracy until the probe is perforated.

A.c. corrosion processes have also indirectly been identified by coulometric oxidation of corrosion products – see Annex C.

8.5 Pipeline metal loss techniques

Internal inspection tools can be used to verify locations of metal loss. If the measurement accuracy and position accuracy are sufficient, then an estimate of the corrosion rate can be made.

9 Mitigation measures

9.1 General

A.c. corrosion can be mitigated by using construction and operation measures. The following subclauses describe measures which can be used individually or in combined application.

9.2 Construction measures

9.2.1 Modification of bedding material

As specific bedding material condition can affect the a.c. corrosion likelihood, the soil condition is of special importance.

This mitigation measure can be implemented at the stage of pipeline installation by bedding it in sand.

Nevertheless, a full embedding status of the pipeline cannot be assured during operation, as the sand could be drained, eluted or mixed with other soil strata, which decreases the effect of the original protection method.

9.2.2 Installation of isolating joints

The a.c. voltage on a pipeline can be reduced by installing isolating joints at suitable positions in the pipeline thus electrically interrupting the longitudinal current path along the pipeline. The effect of this method depends on the reduction of interfering proximity lengths.

NOTE The location of isolating joints can also be influenced by the presence of d.c. stray currents.

The isolating joint locations can be determined during design using simulating models (see CIGRE [1]).

This method can be beneficial where there are extensive parallel routings or high soil resistivities (e.g. greater than 500 Ω .m). In the case of high soil resistivity, the dimensions of the earthing system to mitigate the induced a.c. interference can be significant.

The position of isolating joints should take into account the continuity/discontinuity of a.c. and/or d.c. current distribution along the pipeline.

9.2.3 Installation of mitigation wires

Interference can be also modified by the installation of an insulated wire in close proximity but not connected to the pipeline and between powerline and pipeline. The insulated wire is also earthed at each extremity. This method should not be used as it is considered to be a more effective measure to prevent short term interference rather than a method to reduce long term interference.

In any event, bare wires shall not be used because they can have an adverse effect on coating defect surveys in the case of a coating defect on the pipeline.

9.2.4 Optimisation of pipeline and/or powerline route

The a.c. interference situation on a pipeline mainly depends on the proximity and parallel routing between a pipeline and high voltage power lines. A mitigating effect on the a.c. voltage status can be achieved by increasing the distances between the pipeline and powerline routes.

This requirement often contradicts with the general obligation of joint common 'energy corridors' to minimise environmental impacts.

9.2.5 Power line or pipeline construction

The geometric arrangement of phase conductors or an earthing wire on power line towers will have an effect on the magnitude of the induced voltage on the pipeline and needs to be considered during power line or pipeline construction.

9.3 Operation measures

9.3.1 Earthing

9.3.1.1 General

Mitigating the interference situation by installing earthing systems is the most commonly used method.

Usually horizontal or vertically installed earthing systems are used. The decision on which system to use depends on the local soil resistivities and the local access conditions. The earthing system should have sufficiently low impedance to achieve the required a.c. corrosion protection criteria for induced voltage. Typically, the impedance will need to be less than 10 Ω , although typical configurations require significantly lower values of impedance.

9.3.1.2 Direct earthing

Direct connection of earthing systems to the pipeline is not recommended, particularly if the earthing system is made of copper but also zinc or magnesium. The disadvantages of direct connection are:

- an increased demand on the cathodic protection system shall be considered in addition to the protective pipeline cathodic protection current demand,
- the off potential measurement readings can be misleading,
- cathodic protection effectiveness can be compromised. If this is the case, particular attention should be paid to detrimental galvanic cells (e.g. an earthing system made of copper connected to the pipeline system),
- when magnesium electrodes are used to discharge a.c., they may have a short life,
- there is a tendency for zinc or galvanised steel wires in soil used as earthing system to become more anodic with time. Thus the earthing system can consume more cathodic protection current with time, which will be detrimental to the pipeline corrosion protection system,
- due to the application of cathodic protection current, direct earthing system may be covered by a calcareous layer which, over time, can have an adverse effect on its effectiveness to mitigate a.c. corrosion.

9.3.1.3 Indirect earthing of the pipeline via d.c. decoupling devices

To avoid disadvantages due to direct bonding, earthing systems are commonly not directly bonded to the pipeline but connected via decoupling devices which provide an electrical path for the a.c. current from the pipeline to earth while simultaneously blocking d.c. current.

The d.c. decoupling devices should not interfere with the normal cathodic protection system operation as well as the monitoring of the cathodic protection effectiveness and the touch voltage protection on the pipeline.

The d.c. leakage current for the selected decoupling devices should be taken into consideration when determining the cathodic protection current demand for the pipeline to be cathodically protected.

The most common device used for d.c. decoupling is an electrolytic capacitor. It can be equipped with other electronic devices (in parallel or in series), for safety reasons, for protecting it from surge current, for specific applications.

Annex F gives information to assist in the selection of the correct device to install.

9.3.1.4 A.c. compensation method

If it is not possible to achieve a low resistance earth or if the a.c. voltage is not sufficiently lowered, the decoupling device can be replaced by an a.c. compensation device.

This device compensates the a.c. voltage by imposing a anti-phase a.c. current on the pipeline and thereby generating an artificially zero resistance earth.

9.3.2 Adjustment of cathodic protection level

Adjustment of the cathodic protection level is a method that can be used to mitigate the a.c. corrosion risk on a pipeline by meeting the criteria defined in Clause 7. The adjustment can consist of :

— controlling the CP level towards a more negative level to meet the criterion defined in Clause 7 ($J_{a.c.} / J_{d.c.} < 5$),

or

— controlling the CP level towards less negative level to meet the criterion define in Clause 7 ($J_{d.c.} < 1 \text{ A/m}^2$).

9.3.3 Repair of coating defects

The a.c. corrosion likelihood exists on interfered pipelines especially for small sized coating defects in low resistivity soils (e.g. lower than $25 \Omega.m$). Those sections with coating defects can be surveyed with measurement techniques described in EN 13509. In order to obtain sufficient resolution, the measurement setup should be optimised (increased voltage used for detection and increased resolution of the voltmeter) according to conditions of the pipeline (depth, severity of coating defect).

If an unacceptable a.c. corrosion risk exists on a section of a pipeline despite all the mitigation measures, all coating defects should be excavated and repaired. This is only economically feasible for well coated pipelines.

This method should be combined by measurements on the pipeline to evaluate the a.c. corrosion risk.

A repetition of the measurements to establish a defect free coating condition on a regular basis might be necessary

10 Commissioning

10.1 Commissioning

Although a.c. mitigation systems are not cathodic protection systems, they should be generally commissioned in the same manner as cathodic protection systems as detailed in EN 12954.

It is possible that there will be a.c. voltages at test facilities and exposed sections of pipeline, and whilst these might not be a hazard in themselves they could cause an involuntary reaction that could be hazardous. Safety precautions shall be taken if there is any risk of unacceptable levels of touch potential (see EN 50443).

10.2 Preliminary checking

10.2.1 General

Ensure that appropriate safety precautions are in place.

Before any mitigation devices are connected to the pipeline, a series of measurements should be carried out at various locations to establish the existing levels of a.c. interferences. Selected locations shall include the areas known to experience high levels of interference (see Clause 7) and should include areas that are not considered to suffer from high levels of interference. Interference levels could change adversely when the mitigation measures are applied. The measurements shall be made in accordance with EN 13509. A data logger system is recommended for voltage, current and potential measurements because they should be made over a sufficient period of time (at least 24 h) to accommodate diurnal variations and the measurements made at different locations should be synchronised.

The following measurements should be made and compared with the design or performance values:

- design checks:
 - resistance to earth of the installed earthing system,
 - pipe to soil a.c. voltage and ON-potentials at selected locations,
- installation checks (before having connected any earthing systems):
 - functionality of the mitigation devices,
 - cathodic protection transformer-rectifier settings (if an impressed current system is used),
 - if suitable probes and coupons have been installed then the following additional measurements can be made:
 - ⇒ corrosion rate,
 - ⇒ spread resistance,
 - ⇒ coupon ON and OFF--potential and current,
 - ⇒ coupon a.c. voltage and current.
- commissioning checks (after having connected any earthing systems):
 - pipe to soil a.c. voltage and ON and OFF- potentials at selected locations,
 - if suitable probes and coupons have been installed then the following additional measurements can be made:
 - ⇒ corrosion rate,
 - ⇒ coupon ON and OFF- potential and current,
 - ⇒ coupon a.c. voltage and current.

10.2.2 Start up

The start up should be carried out as shown below, unless the requirements given in EN 50443 are exceeded with mitigation devices disconnected:

- a) Carry out the data logging and measurement procedures during the installation and commissioning checks before commencing any start up procedures.
- b) Check touch potentials by measurement. If there are unacceptable levels of touch potential, then suitable precautions shall be taken (see EN 50443).

- c) Connect the mitigation device to the earthing system via the pre-arranged connection; then connect the other terminal of the mitigation device to the pipeline. Repeat this procedure for all mitigation devices.

10.2.3 Verification of effectiveness

The effectiveness of the mitigation system can be demonstrated by showing that criteria defined in Clause 7 are achieved. The same measurements as those conducted during commissioning can also be made (see 10.2.2).

Measurements should be performed on pipelines or sections of them where unacceptable a.c. influence is suspected or can be expected based on map observation, calculation, or routine measurements. These measurements should be performed, in the first instance, at all test points, cathodic protection stations, insulating joints and casings, and wherever an accessible measurement cable is connected to the pipeline or section.

A coupon or probe could be used at the areas identified as being at a high risk of a.c. corrosion to determine the current density and/or the corrosion rate (see 8.4).

Additionally the effectiveness of the mitigation system can also be determined by a reduction in corrosion rate since this accurately represents the total effectiveness of the applied cathodic protection system as well as the a.c. mitigation system.

10.2.4 Installation and commissioning documents

After the completion of the commissioning checks a file of documents shall be prepared. The following information should be provided:

- as built drawings of the installation.
- design documentation, which should include the detailed specification of any devices installed.
- results of data logging and potential measurements before connection of the mitigation system.
- results of data logging and potential measurements after connection of the mitigation system.
- recommendations for long-term monitoring of the induced a.c. levels and their impact on the external corrosion of the pipeline (this can include remote monitoring and coating defect surveys).
- an operation and maintenance manual.

These documents should be retained by the pipeline operator or the responsible body for the integrity of the pipeline system.

11 Monitoring and maintenance

A.c. measurements and controls should be integrated into the routine monitoring of cathodic protection systems and included in the maintenance procedures.

In the areas where the interference from a.c. systems is known, the maintenance procedures should include:

- measurements of a.c. voltage,
- measurements of ON-potential,
- measurements of ON and/or OFF potential and a.c. voltage on coupons or probes,
- a.c. and d.c. current densities on coupons or probes,

- measurements of corrosion rate on probes,
- measurements of d.c. and a.c. current on existing d.c. decoupling devices through all earthing systems,
- measurements of the electrical resistance of the earthing systems.

Measurements shall be made according to Clause 8 and on selected test points. Measurement frequencies shall be in accordance with those given in EN 12954. As the corrosion risk is higher on a pipeline with an a.c. voltage, the operator shall pay special attention to the frequency at which measurements are taken and how the measurements are performed.

Annex A (informative)

Simplified description of the a.c. corrosion phenomenon

A.1 Cathodically protected pipeline

The cathodic protection of pipelines forces current to enter the pipeline through the metal surface in contact with soil where the coating is damaged. This current prevents corrosion from taking place by removing oxygen from the soil and eliminating potential differences along the pipeline. Moreover the cathodic current results in the increase of the alkalinity on the steel surface.

A.2 Cathodically protected pipeline with a.c. voltage

A.2.1 Description of the phenomena

When an a.c. voltage is present on a cathodically protected pipeline, current will flow through the metal surface at defects in the coating. The amount of current flowing depends on the a.c. voltage and the impedance of the system. During the cathodic half wave the amount of current entering the steel surface and therefore the rate of the cathodic reactions on the metal surface generally increases. During the anodic half wave of the a.c. voltage, the current will leave the metal surface, if the a.c. voltage is sufficiently large. A current leaving the metal surface is associated with oxidation reactions and can, therefore, cause corrosion.

The current leaving the metal surface can cause charging of the double layer capacitance, oxidation of hydrogen where present and corrosion products (e.g. reduced by the cathodic protection current), and oxidation of the pipeline steel. If the pH-value is sufficiently high (above 10) this oxidation of the pipeline steel can result in the formation of an oxide film. In contrast, current entering the metal surface can result in the charging of the double layer capacitance, reduction of oxygen, formation of hydrogen, and reduction of oxidised corrosion products. Furthermore, the oxide film formed during the anodic half wave can at least partly be electrochemically reduced.

Empirically it has been observed that both, very high and very low d.c. current densities can prevent a.c. corrosion. In the case of very high d.c. current densities this effect can be associated with the increase of the pH at the steel surface, the resulting decrease of the spread resistance, and the increased electrochemical reduction reactions taking place on the steel surface. These effects result in increased a.c. and d.c. current densities, larger charges passed during the anodic and cathodic half wave, changes in the solubility of oxidation products of iron and their oxidation state.

A very simplified description of the process taking place during a.c. corrosion is shown in Figure A.1. During the anodic half wave the bare metal surface is oxidised resulting in the formation of an oxide film. This is due to the current that leaves the metal surface. During the negative half wave, when the current enters the metal surface, this oxide film is reduced and, therefore, converted into a non-protective rust layer. In the following anodic cycle a new oxide film grows. Upon reduction of the oxide film, the amount of rust is increased. If this process results in the formation and dissolution of a single oxide layer during every anodic half wave, corrosion rates in the range of 100 mm/year would be obtained. Since such high corrosion rates were only achieved under extreme laboratory conditions, it can be concluded that the formation and/or reduction of the oxide film is, in most cases, only partially taking place.

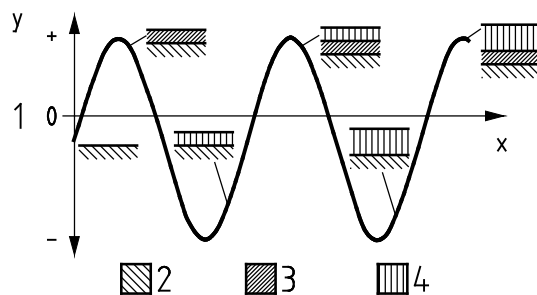

Key

- | | | | |
|---|--|---|---|
| 1 | a.c. current present on a coating defect | 2 | metal |
| 3 | passive film (e.g. Fe_3O_4) | 4 | iron hydroxide (e.g. $\text{Fe}(\text{OH})_2$) |
| X | time | Y | current |

**Figure A.1 — Graph of cathodic protection current with a.c. influence —
 Schematic description of the a.c. corrosion process with cathodic protection**

A.2.2 Reduction of the a.c. corrosion rate

Based on this concept, it is possible to discuss several empirical observations. The a.c. corrosion process only takes place if the oxide film is formed (at least partly) and dissolved (at least partly). If the formation of an oxide film is prevented by sufficiently high d.c. current densities at sufficiently low a.c. current densities, a.c. corrosion can be stopped. Similarly, a.c. corrosion can be stopped if the cathodic reduction (dissolution) of the once formed oxide film is prevented. This is possible by sufficiently limiting the cathodic current density. Additionally, the decreased a.c. corrosion rate at low d.c. current densities could be a result of the lower pH-value at the metal surface and the higher spread resistance of the metal surface.

Based on this consideration, it is clear that both, high and low d.c. current densities can prevent a.c. corrosion. This has to be taken into account in the discussion of threshold values since there are two fundamentally different concepts of prevention of a.c. corrosion. The concept allows the explanation of the relevance of the various thresholds, such as the existence of a critical ratio between a.c. and d.c. current density, and of a critical a.c. current density.

Annex B (informative)

Coupons and probes

B.1 Use and sizes of coupons and probes

B.1.1 Use of coupons or probes

A.c. voltage on a pipeline can cause corrosion in normal operating conditions of the a.c. source (power line or railway line). This a.c. voltage may be induced or flows on the pipeline from a.c. power sources.

The a.c. corrosion risk can be evaluated by measurements on coupons or probes installed on the pipeline. They can be installed permanently or temporarily. So, measurements made with coupons or probes can be compared to criteria defined in this European Standard.

The a.c. corrosion risk can be also evaluated by corrosion rate measurements on probes or coupons. The corrosion rate can be measured by the ER probe technique or by visible corrosion on a "removable" coupon, which is buried near the pipeline. This last kind of coupon is usually used when other techniques do not provide results that can be compared to the criteria.

B.1.2 Sizes of coupons or probes

Most of the time, a.c. corrosion is observed on pipelines with an efficient coating with only small coating defects.

At a given potential, current density (a.c. and d.c.) is higher on small coating defects. For this reason, it is preferable to use small surface area probes or coupons to perform a.c. measurements (e.g. U.a.c. and I.a.c.).

A.c. current density studies and measurements are made with circular probes or coupons with 1 cm² exposed surface area. For a.c. interference measurements, the 1 cm² surface area has been adopted as a universal standard.

B.2 Installation of buried coupons and probes

B.2.1 General

The following is a typical procedure for the installation of coupons or probes by an augering technique.

B.2.2 Before installing the coupon or probe

Locate and identify all buried structures including piping, tanks, and cables prior to the installation of any probes or coupons. Select a point to auger - take proper precautions not to damage the coating or structure when augering. Preferably, the backfill zone should be known in advance (see Figure B.1). Make a mark (for instance on the test post) defining a depth of zero.

Drill a hole using an auger, or an equivalent method, preferably to the pipe invert level to install a coupon or probe. The hole should be installed about 20 cm from the pipeline. While collecting the soil record the nature of any different soil layer/types (top layers, middle layers, bottom layers etc.) in order to be able to relocate the soil profile on completion of the hole. It is of particular importance to refill the bottom layer soil that would be present around the pipeline when the coupon or probe is installed.

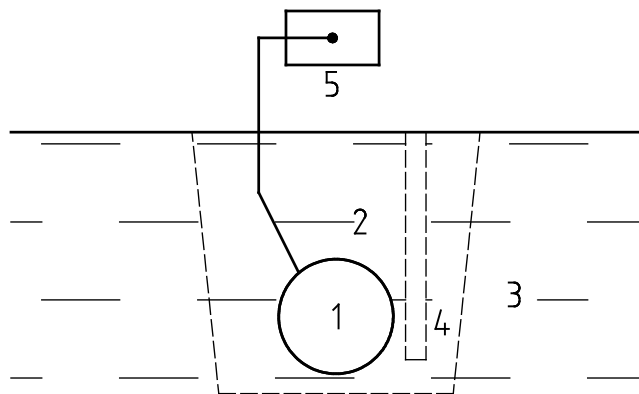

Key

- | | | | |
|---|-------------|---|--------------|
| 1 | pipe | 2 | backfill |
| 3 | native soil | 4 | augered hole |
| 5 | test post | | |

Figure B.1 — Drilled hole next to a pipeline

If desired for characterisation of the soil type, it is advisable to use some of the excavated soil to perform soil resistivity testing in a soil box, to determine the soil moisture content, to conduct an acid droplet test for presence of calcium carbonate or to obtain a sample for further analysis. The detailed soil analysis can be conducted in a laboratory.

B.2.3 Installation of the buried coupon or probe

Push the coupon or probe into position. If the soil is soft / sandy push the coupon or probe an additional step down through the undisturbed native soil/backfill. In this case, the soil usually fills out and compacts around the coupon or probe and provides a good electrical connection.

If the soil is harder, it might be necessary to sample an amount of soil from the desired coupon or probe depth and form a “cake” around the artificial coating defect of the coupon or probe – mixed with a small quantity of distilled water prior to positioning in the soil.

Fill back the soil in the drilled hole in the same manner as uncovered and compact each small amount of backfill and arrange the coupon or probe test leads in the test post (see Figure B.2). Preferably, the coupon or probe should be equipped with a double wired connection. One connection between the coupon or probe and the pipe is essential to carry out measurements; a second connection makes measurements easier and more reliable.

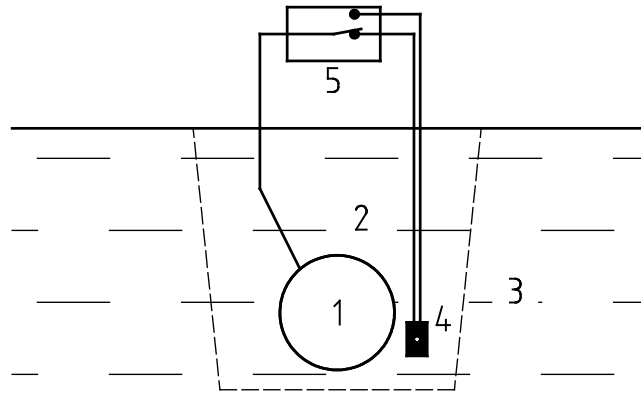

Key

- | | |
|---|-------------------|
| 1 pipe | 2 backfill |
| 3 native soil | 4 coupon or probe |
| 5 test post with switch (normally closed) | |

Figure B.2 — Coupon or probe positioned next to the pipeline and connected through a test post

B.3 ER probes principles

B.3.1 Assessment of the corrosion using the electrical resistance (ER) probe technique

B.3.1.1 General theory

The ER probe technique can be applied for corrosion rate assessment as an alternative to the weight loss coupon. Unlike the weight loss coupon, the ER probe technique does not require excavation and weighing procedures, since a mass loss is assessed by electronic means.

Other probe electrical characteristics such as a.c. current density, d.c. current density, leakage resistance etc are also measured on ER probes as described in Clause 8.

The ER technique measures the change of the resistance of a metal element formed as a coupon. When the metal element suffers metal loss due to corrosion the electrical resistance of the element will increase. Since the resistance of the element also changes due to temperature variations, a second element which is coated in order to protect it from corrosion is utilised for temperature compensation. The element exposed to the corrosive environment constitutes the coupon part of the element, whereas the element protected from corrosion by the coating constitutes a reference element (see Figure B.3). The two are thermally connected in order to efficiently equalise any temperature difference between the two elements.

The resistance values of the two individual elements are usually measured by passing an excitation current through the elements and measuring the voltage generated over the element caused by the excitation current.

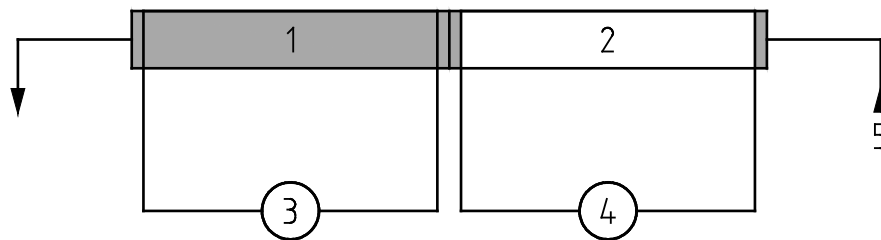

Key

- | | |
|---|--|
| 1 reference element - R _r | 2 coupon element - R _c |
| 3 voltage across the reference element - V _R | 4 voltage across the coupon element - V _C |
| 5 excitation current I _{exc.} | |

Figure B.3 — Principle of ER probe with excitation current and voltage measurements

B.3.1.2 Mathematical development to determine V_{corr}

Referring to simple plate geometry, the electrical resistance of the element can be expressed by:

$$R = \rho(T) \cdot \frac{L}{W \cdot d} \tag{B.1}$$

where L is the length of the element, W is the width of the element, and d is the element thickness in metres. The resistivity of the element material in ohm metres $\rho(T)$ can be expressed as:

$$\rho(T) = \rho(T_0) \cdot (1 + \alpha)^{T - T_0} \tag{B.2}$$

In this formula, T is the temperature, T₀ is a reference temperature, $\rho(T_0)$ is the resistivity of element material at the reference temperature and α is the specific temperature coefficient of the element material.

Re-arranging Formula (B.1) gives the thickness of element expressed as a function of element resistance:

$$d = \rho(T) \cdot \frac{L}{W} \cdot \frac{1}{R} \tag{B.3}$$

Differentiation of this formula gives the corrosion rate of the element as:

$$V_{\text{corr}} = -\frac{dd}{dt} = \frac{dR}{dt} \cdot \frac{W}{L} \cdot \frac{d^2}{\rho(T)} \tag{B.4}$$

B.3.1.3 V_{corr} assessment

By quantifying the time change of the electrical resistance combined with knowledge of the element dimensions and resistivity, the corrosion rate can be assessed. It follows that by re-arranging Formula (B.4) the period of time needed to quantify a certain corrosion rate can be assessed by:

$$\Delta t = \frac{\Delta R}{V_{\text{corr}}} \cdot \frac{W}{L} \cdot \frac{d^2}{\rho(T)} \tag{B.5}$$

The Formula predicts that the necessary period of time increases with increasing W/L ratio, and increases with the square of the element thickness. Hence, high sensitivity ER probes can be enhanced by using thinner elements, but this decreases the probe lifetime as well.

In Formula (B.5), ΔR can be regarded as the minimum resistance change required to provide a reliable measurement. Improvement of the resolution of the applied resistance measurement technique then allows for

shortening of the necessary period of time required to quantify a certain corrosion rate without compromising in terms of coupon element lifetime.

For simple practical purposes, the thickness of the coupon element at time t can be assessed throughout time using the sketched circuit principle. The coupon element thickness at time t is then quantified by a mathematical algorithm, for instance:

$$d(t) = d(t=0) \cdot \frac{R_r(t)}{R_c(t)} \cdot \frac{R_c(t=0)}{R_r(t=0)} \quad (\text{B.6})$$

where $(t = 0)$ refers to the initial probe conditions. The slope of a thickness versus time curve can be used for simple assessment of the corrosion rate.

B.3.1.4 Specific recommendation for ER probe

Since a high level of a.c. current can pass through the coupon element, local heating of the coupon element compared with the reference element could be expected. For this reason, ER probes should be disconnected from the pipeline and left in an open circuit condition for a short period of time until thermal equilibrium is reached before the ER measurement is made. This will ensure the best possible assessment of the element thickness in accordance with Formula (B.6).

B.3.2 ER probe application in the field

When using an ER probe, a range of informative indicators (ON and/or OFF-potential, the d.c. current density, the a.c. current density and the spread resistance) can be monitored simultaneously. These indicators give valuable information on any cause of corrosion – in the present case a.c. corrosion. A typical a.c. corrosion scenario involves a condition of decrease in the spread resistance throughout time – usually caused by a high level of d.c. current density – which in combination with a sufficient a.c. voltage creates increasing high levels of a.c. current density. Eventually, the corrosion rate will increase rapidly to values that are typically significantly higher than 0,01 mm per year.

Using this concept, a pipeline system which is in actual danger of a.c. corrosion can typically reveal spikes in the ER probe corrosion rates due to changes in the electrical condition. In this manner, by carefully analyzing the electrical parameters that are causing such spikes, the threshold values for corrosion can be deduced and built into the record kept for a particular location, based on the threshold corrosion rate and the threshold protection potentials defined in EN 12954.

The above concept is also applicable for other types of corrosion e.g. corrosion caused by d.c. stray current and makes it a versatile tool.

B.4 Perforation probes

The perforation probe can be used instead of a conventional coupon. The levels of a.c. and d.c. interference and the current density can be measured. Additionally the time when a critical predetermined corrosion depth is reached can readily be determined. Hence, the efficiency of the measures taken to decrease the a.c. corrosion rate can be verified in the field.

The probe consists of a thin steel plate with a thickness in the range of 0,1 mm to 1 mm and an internal electrode. The thin steel plate is on one side in contact with the soil and on the other side with an insulator separating the internal electrode and the steel plate. When corrosion perforates this steel plate, humidity will penetrate into the gas-tight coupon and form a conductive electrolyte between the electrode and the thin steel plate. By a simple resistance measurement between the electrode and the thin plate the perforation of the coupon can be detected by means of conventional resistance measurement devices. As a consequence, the monitoring of the perforation probe can be readily integrated into a conventional inspection routine or monitored over time. The key advantage is the simple handling and especially the information about the corrosion depth. Hence, information about the depth of the corrosion is provided independent on corroding surface. This is especially important in cases of very local corrosion that penetrates rapidly, but with little mass loss.

The main application purpose is to ensure that the threshold values for the current density are met. Since these current values are averaged over the entire probe surface the actual local current density can be underestimated in the case of the formation of chalk layers on the probe surface. Therefore the perforation probes provide an additional safety level by giving an alarm value. It is the only coupon that provides information on corrosion depth even in the case of very local corrosion attack.

Annex C (informative)

Coulometric oxidation

The application of cathodic protection current results in an increased pH value and in an electrochemical reduction of some of the corrosion products formed on the steel surface from Fe^{3+} to Fe^{2+} . The overall quantity of iron ions accumulated due to corrosion can be estimated by electrochemical oxidation of Fe^{2+} to Fe^{3+} in the corrosion products. As a consequence, the amount of charge required for oxidation is proportional to the amount of corrosion product formed over time. The coulometric oxidation can be performed with all types of coupons or probes installed in the field and connected to a cathodically protected pipeline.

By isolating the coupon or probe from the pipeline, a constant anodic current can be applied and the resulting potential can be recorded. The ohmic potential drop can be numerically corrected or the off-potential can be determined by periodically interrupting the current flow. The amount of charge required to polarise the coupon or probe to 0 V vs CSE is used for estimating the mass loss on the coupon or probe. By multiplying the charge in Coulombs by 0,013 the mass loss in grams is obtained. The advantage of the technique is the possibility of determining the extent of corrosion that occurred in the past. Moreover, the further increase in extent of corrosion can be determined by means of repeated coulometric oxidation measurements. The results of the measurements are only reliable, if all the corrosion products are electrochemically accessible and if the cathodic protection current is sufficiently high enough to reduce all the corrosion products.

Annex D (informative)

Influence of soil characteristics on the a.c. corrosion process

D.1 Influence of electrical parameters

The a.c. current density at a coating defect is essentially determined by the induced a.c. voltage on the pipeline and the coating fault resistance. Generally a low coating fault resistance is observed in soil with low specific electrical resistivity resulting in a higher a.c. corrosion likelihood for a given a.c. voltage.

D.2 Influence of the electrochemical process

The specific local soil resistivity is controlled by the amount of soluble salts and the soil moisture content. Therefore, significant differences in the coating fault resistance can be observed if the pipeline is above or below the water table level. Additionally, the coating fault resistance is strongly influenced by the electrochemical processes taking place on the bare metal surface, due to the application of cathodic protection current.

The electrochemical reduction of oxygen or the evolution of hydrogen results in an increase of the pH value on the metal surface. Typically, the pH value is above 11 and can reach values up to 14 or possibly even higher in extreme cases.

D.3 Influence of alkaline ions and cations

The cathodic protection current results in a migration of cations to the metal at the coating fault, which interact with the locally increased pH value. Depending on the soil composition, the coating fault resistance can either increase or decrease over time. Indeed, the following modifications of the soil environment can appear according to the increase of the pH value, i.e. formation of NaOH or CaCO₃.

The earth alkaline ions Ca²⁺ and Mg²⁺ form hydroxides that exhibit a relatively low solubility. With the increase of the pH, their precipitation will take place near any coating holiday. The reaction of these hydroxides with the CO₂ present in the soil results in the formation of calcareous deposits. If a dense calcareous deposit is formed directly on the metal surface at the holiday, the coating fault resistance can significantly increase several orders of magnitude.

Whilst the earth alkaline ions generally increase pore resistance, the alkaline cations Na⁺, K⁺ and Li⁺ result in the formation of highly soluble hygroscopic hydroxides. As a consequence, a low spread resistance due to the attracted water and high ion concentration is observed. This process can decrease the pore resistance of the metal at a coating fault by up to a factor of 60.

The current density on the metal at coating fault of a given geometry is therefore dependent on the electrical conductivity and the ratio of alkali and earth alkali ions. Moreover, the cathodic current density influences the amount of hydroxide produced and affects, therefore, the local conductivity.

Annex E (informative)

Other criteria that have been used in the presence of a.c. influence

E.1 General

These criteria, though not widely used, have been successfully applied by some operators. They have defined them by either field and/or laboratory experiments. They are included in this informative annex for the sake of completeness.

A.c. values are rms ones. Current densities are measured on a 1 cm² circular coupon or probe.

E.2 ON-potential approach

E.2.1 General

The ON and the IR free potentials control the level of CP applied as the driving voltage is defined by the difference between the ON and the IR free potentials. The intensity of the cathodic protection current able to reach and polarise the steel surface at a coating defect depends on the driving potential and on the total circuit resistance according to Ohm's law.

The consideration of the corrosion likelihood based on the ON-potential is only possible when the chosen concept for a.c. corrosion prevention is known.

Technical papers related to the protection and mitigation measures associated with a.c. corrosion likelihood on cathodically protected pipelines are given referenced in the Bibliography (see [5], [6] and [7]).

E.2.2 More negative (Eon) cathodic protection level

When a negative ON-potential results in high cathodic current density, it can result in a strong change in the soil chemical composition, spread resistance and an increased reduction of oxide layers (see Annex A). A.c. corrosion can be prevented when applying a sufficiently negative ON-potential to avoid any metal oxidation due to the presence of a.c. interference. As a consequence, the required level of the ON-potential is related to the induced a.c. voltage on the pipeline.

E.2.3 Less negative (Eon) cathodic protection level

A relatively positive ON-potential has only a limited effect on spread resistance. While having no adverse effect on the coating adhesion and resulting in a low hydrogen evolution rate it can result in insufficient cathodic protection according to the limiting critical potential criteria indicated in EN 12954. The primary advantage of a more positive ON-potential is the generally higher acceptable a.c. voltages. When choosing a.c. corrosion prevention system based on a less negative Eon cathodic protection level, it might be necessary to install additional CP stations. Since current flow due to the ON-potential depends on the level of the OFF-potential and also on soil resistivity and defect geometry, it is difficult to judge the a.c. corrosion likelihood based on the ON-potential alone in the case of less negative cathodic protection levels. However, applying an ON-potential criterion that is as positive as possible, while still maintaining the off potentials given in EN 12954, will result in a decreased a.c. corrosion likelihood.

E.2.4 Criteria

The criteria as defined in EN 12954 should be respected.

Theoretical and practical experiences have shown that there are two methods that can be used to solve a.c. influence problems against steel corrosion:

- 1) first scenario: "more negative" cathodic protection level. In this case, one of the three parameters below, in order of priority, can be applied:

— The following formula should be satisfied:
$$\frac{U_{a.c.}}{|E_{on}| - 1,2} < 3.$$

Note that in this case it is important to ensure that there is no corrosion risk due to cathodic disbondment and no adverse effect caused by hydrogen evolution.

or

— a.c. current density $< 30 \text{ A/m}^2$,

or

— $\frac{I_{a.c.}}{I_{d.c.}} < 3$ if a.c. current density $> 30 \text{ A/m}^2$.

In this case it is important to ensure that there is no corrosion risk due to cathodic disbondment and no adverse effect from hydrogen evolution.

- 2) second scenario: "less negative" cathodic protection level. In this case, one of three parameters below, in order of priority, can be used:

— $U_{a.c. \text{ average}} < 15 \text{ V}$ if the average E_{on} is more positive than $-1,2 \text{ V CSE}$,

or

— average a.c. current density $< 30 \text{ A/m}^2$,

or

— cathodic protection average current density $< 1 \text{ A/m}^2$ if a.c. average current density $\geq 30 \text{ A/m}^2$.

A.c. voltage and d.c. potential should be determined with the same reference electrode placed at the same location (preferably at remote earth).

Figures E.1 and E.2 illustrate limits for scenarios for different a.c. and d.c. current densities in terms of a.c. corrosion likelihood, and also for ON potential and a.c. voltage in terms of a.c. corrosion likelihood.

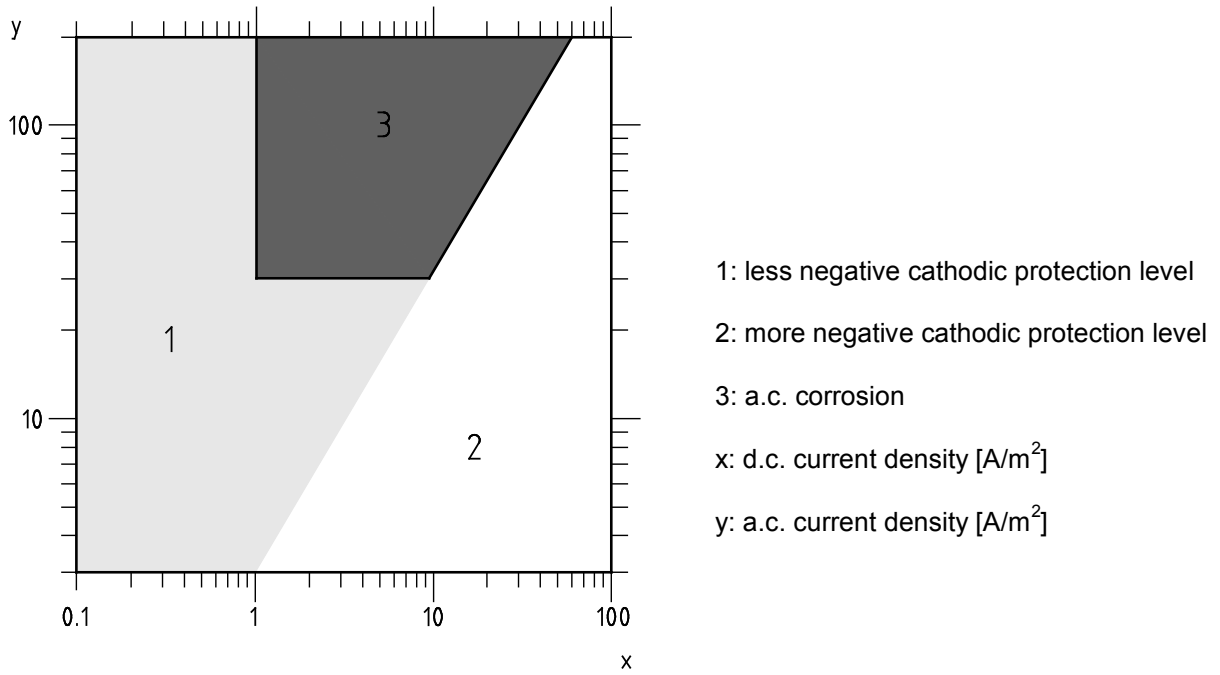

Figure E.1 – Relationship between d.c. and a.c. current densities and likelihood of a.c. corrosion

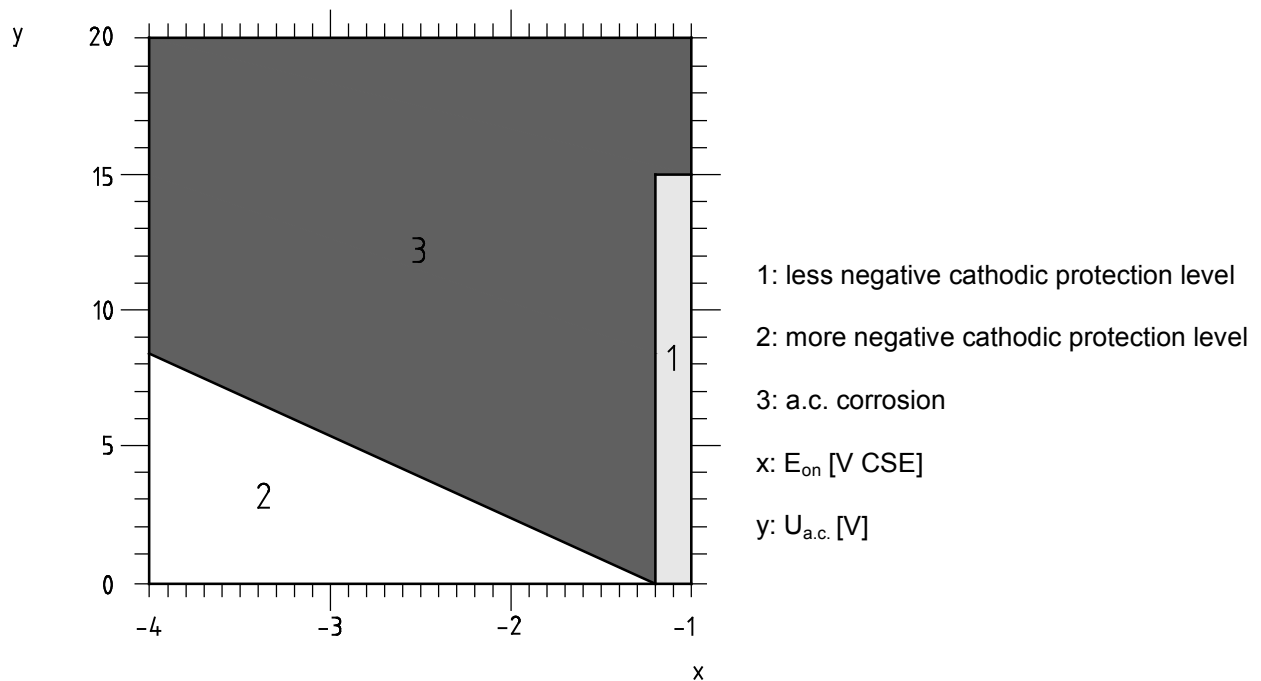

Figure E.2 – Relationship between d.c. ON potential, a.c. voltage and likelihood of a.c. corrosion

NOTE Axis limits for x are given for information. In practice, it is possible to have higher axis ranges.

Annex F (informative)

Parameters to take into account to choose a d.c. decoupling device

This annex gives information to help select the most suitable a.c. mitigation system to install.

F.1 General aspects to be taken into account

- A.c. voltage mitigation effectiveness and respective a.c. corrosion risk mitigation methods
- Resistance to earth of a.c. mitigation electrode
- Influence on cathodic protection operation and monitoring
- Existence of a.c. voltage/current activation threshold
- Ability to withstand and/or conduct surges and lightning overvoltages
- Size of the device
- Maintenance

F.2 Electrical parameters

- Capacitance
- Activation a.c. voltage level
- Activation a.c. current level
- Deactivation a.c. voltage level
- Deactivation a.c. current level
- D.c. leakage vs. d.c. voltage or cathodic protection potential of the pipeline
- D.c. leakage ratio to total cathodic protection current consumption of the pipeline
- Max. continuous a.c. current
- Steady-state a.c. current vs. a.c. voltage
- D.c. nominal Voltage range (min.-max.)
- A.c. nominal Voltage range (min.-max.)
- Frequency
- A.c. impedance
- D.c. resistance
- Ability to withstand and/or conduct surges and lightning overvoltages, e.g.:
 - Voltage protection level at surges
 - Transient kA (8/20 μ s)
 - Transient kA-nominal impulse discharge current (10/350 μ s)
 - A.c. current for 10 s for 50 Hz
 - A.c. current for 0,2 s for 50 Hz
 - A.c. fault current kA
 - A.c. sparkover voltage
 - D.c. sparkover voltage

Annex G (informative)

Method to determine the reference electrode location to remote earth

The applicable position of remote earth may be assessed using the arrangement shown in Figure G.1. This is particularly important when measuring nearby earth electrodes.

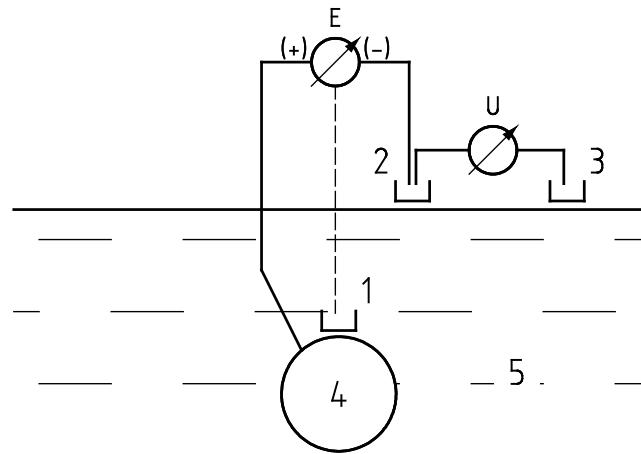

Key

- 1, 2 & 3 reference electrode locations
4 pipe
5 soil

Figure.G.1 — Measurement of the a.c. gradient and localising remote earth

Reference electrode (1) represents the IR free condition and is not applicable for a.c. voltage measurements since – with reference to remote earth – the entire IR drop should be included.

Instead the following procedure can be useful:

- 1) Place a reference electrode (2) on top of the soil above the pipeline. Connect a (first) voltmeter to the pipeline and this reference electrode and read the a.c. voltage.
- 2) Place an additional reference electrode (3) on top of the soil above the pipeline. Connect a second voltmeter between reference electrodes (2) and (3) and read the a.c. voltage difference between the two reference electrodes.
- 3) Change the position of reference electrode (3) 1 m to 5 m transverse to the pipeline and read the a.c. voltage on the voltmeters.
- 4) Put reference electrode (2) to the former position of reference electrode (3) and read the a.c. voltage on the voltmeters.
- 5) Remote earth is reached when repeating steps 3 and 4 continuously does not change the a.c. voltage value of the reading of the second voltmeter, which should be close to zero.
- 6) Finally place electrode (2) where electrode (3) indicated the remote earth position, connect the voltmeter with electrode (2) and read the AC voltage with electrode (2).

Bibliography

- [1] CIGRE Technical Brochure N°95 published in 1995 *“Guide on the Influence of High Voltage a.c. Power Systems on Metallic Pipelines*
- [2] EN ISO 8044:1999, *Corrosion of metals and alloys — Basic terms and definitions (ISO 8044:1999)*
- [3] IEC 60050-826:2004, *International electrotechnical vocabulary — Part 826: Electrical installations*
- [4] IEC 60050-195:1998, *International electrotechnical vocabulary — Part 195: Earthing and protection against electric shock*
- [5] M. Büchler, C.-H. Voûte und D. Joos, „Feldversuche zur Wechselstromkorrosion“, *DVGW - energie/wasser-praxis* July/August 2010, 30 (2010)
- [6] M. Büchler, C.-H. Voûte and D. Joos, „Field investigation of a.c. corrosion“, *CEOCOR International Congress 2011 Menthon-Saint-Bernard CEOCOR, c/o SYNERGRID, Brussels, Belgium, 2011*
- [7] M. Büchler, „Alternating current corrosion of cathodically protected pipelines: Discussion of the involved processes and their consequences on the critical interference values“, *Materials and Corrosion*; in press (2012)
- [8] EN 15257, *Cathodic protection — Competence levels and certification of cathodic protection personnel*
- [9] ISO 8407:2009, *Corrosion of metals and alloys — Removal of corrosion products from corrosion test specimens*

British Standards Institution (BSI)

BSI is the national body responsible for preparing British Standards and other standards-related publications, information and services.

BSI is incorporated by Royal Charter. British Standards and other standardization products are published by BSI Standards Limited.

About us

We bring together business, industry, government, consumers, innovators and others to shape their combined experience and expertise into standards-based solutions.

The knowledge embodied in our standards has been carefully assembled in a dependable format and refined through our open consultation process. Organizations of all sizes and across all sectors choose standards to help them achieve their goals.

Information on standards

We can provide you with the knowledge that your organization needs to succeed. Find out more about British Standards by visiting our website at bsigroup.com/standards or contacting our Customer Services team or Knowledge Centre.

Buying standards

You can buy and download PDF versions of BSI publications, including British and adopted European and international standards, through our website at bsigroup.com/shop, where hard copies can also be purchased.

If you need international and foreign standards from other Standards Development Organizations, hard copies can be ordered from our Customer Services team.

Subscriptions

Our range of subscription services are designed to make using standards easier for you. For further information on our subscription products go to bsigroup.com/subscriptions.

With **British Standards Online (BSOL)** you'll have instant access to over 55,000 British and adopted European and international standards from your desktop. It's available 24/7 and is refreshed daily so you'll always be up to date.

You can keep in touch with standards developments and receive substantial discounts on the purchase price of standards, both in single copy and subscription format, by becoming a **BSI Subscribing Member**.

PLUS is an updating service exclusive to BSI Subscribing Members. You will automatically receive the latest hard copy of your standards when they're revised or replaced.

To find out more about becoming a BSI Subscribing Member and the benefits of membership, please visit bsigroup.com/shop.

With a **Multi-User Network Licence (MUNL)** you are able to host standards publications on your intranet. Licences can cover as few or as many users as you wish. With updates supplied as soon as they're available, you can be sure your documentation is current. For further information, email bsmusales@bsigroup.com.

BSI Group Headquarters

389 Chiswick High Road London W4 4AL UK

Revisions

Our British Standards and other publications are updated by amendment or revision.

We continually improve the quality of our products and services to benefit your business. If you find an inaccuracy or ambiguity within a British Standard or other BSI publication please inform the Knowledge Centre.

Copyright

All the data, software and documentation set out in all British Standards and other BSI publications are the property of and copyrighted by BSI, or some person or entity that owns copyright in the information used (such as the international standardization bodies) and has formally licensed such information to BSI for commercial publication and use. Except as permitted under the Copyright, Designs and Patents Act 1988 no extract may be reproduced, stored in a retrieval system or transmitted in any form or by any means – electronic, photocopying, recording or otherwise – without prior written permission from BSI. Details and advice can be obtained from the Copyright & Licensing Department.

Useful Contacts:

Customer Services

Tel: +44 845 086 9001

Email (orders): orders@bsigroup.com

Email (enquiries): cservices@bsigroup.com

Subscriptions

Tel: +44 845 086 9001

Email: subscriptions@bsigroup.com

Knowledge Centre

Tel: +44 20 8996 7004

Email: knowledgecentre@bsigroup.com

Copyright & Licensing

Tel: +44 20 8996 7070

Email: copyright@bsigroup.com