



## Standard Test Method for Laboratory Evaluation of Magnesium Sacrificial Anode Test Specimens for Underground Applications<sup>1</sup>

This standard is issued under the fixed designation G 97; the number immediately following the designation indicates the year of original adoption or, in the case of revision, the year of last revision. A number in parentheses indicates the year of last reapproval. A superscript epsilon (ε) indicates an editorial change since the last revision or reapproval.

<sup>ε1</sup> NOTE—Cautionary notes were moved into the section text editorially October 2002.

### 1. Scope

1.1 This test method describes a laboratory procedure that measures the two fundamental performance properties of magnesium sacrificial anode test specimens operating in a saturated calcium sulfate, saturated magnesium hydroxide environment. The two fundamental properties are electrode (oxidation potential) and ampere hours (Ah) obtained per unit mass of specimen consumed. Magnesium anodes installed underground are usually surrounded by a backfill material that typically consists of 75 % gypsum ( $\text{CaSO}_4 \cdot 2\text{H}_2\text{O}$ ), 20 % bentonite clay, and 5 % sodium sulfate ( $\text{Na}_2\text{SO}_4$ ). The calcium sulfate, magnesium hydroxide test electrolyte simulates the long term environment around an anode installed in the gypsum-bentonite-sodium sulfate backfill.

1.2 This test method is intended to be used for quality assurance by anode manufacturers or anode users. However, long term field performance properties may not be identical to property measurements obtained using this laboratory test.

NOTE 1—Refer to Terminology G 15 for terms used in this test method.

1.3 *This standard does not purport to address all of the safety concerns, if any, associated with its use. It is the responsibility of the user of this standard to establish appropriate safety and health practices and determine the applicability of regulatory limitations prior to use.* For specific precautions, See Section 7 and Paragraph 8.1.1.

### 2. Referenced Documents

#### 2.1 ASTM Standards:

D 1193 Specification for Reagent Water<sup>2</sup>

G 3 Practice for Conventions Applicable to Electrochemical Measurements in Corrosion Testing<sup>3</sup>

G 15 Terminology Relating to Corrosion and Corrosion Testing<sup>3</sup>

<sup>1</sup> This test method is under the jurisdiction of ASTM Committee G01 on Corrosion of Metals, and is the direct responsibility of Subcommittee G01.10 on Corrosion in Soils.

Current edition approved Oct. 10, 1997. Published December 1997. Originally published as G 97 – 89. Last previous edition G 97 – 89 (1995)<sup>ε1</sup>.

<sup>2</sup> *Annual Book of ASTM Standards*, Vol 11.01.

<sup>3</sup> *Annual Book of ASTM Standards*, Vol 03.02.

G 16 Guide for Applying Statistics to Analysis of Corrosion Data<sup>3</sup>

#### 2.2 American National Standard:

ANSI/NFPA 480 Storage, Handling, and Processing of Magnesium, 1987 Edition<sup>4</sup>

### 3. Summary of Test Method

3.1 A known direct current is passed through test cells connected in series. Each test cell consists of a pre-weighed test magnesium alloy anode specimen, a steel pot container cathode, and a known electrolyte. Test specimen oxidation potential is measured several times during the 14-day test and 1 h after the current is turned off at the end of the test. The total Ah passed through the cells are measured. At the conclusion of the test, each test specimen is cleaned and weighed. The Ah obtained per unit mass of specimen lost is calculated.

### 4. Significance and Use

4.1 This test is a guide for evaluating magnesium anodes. The degree of correlation between this test and service performance has not been fully determined.

### 5. Apparatus

5.1 The basic test equipment consists of the following:

5.1.1 *Direct Current Power Source*, (optional), capable of delivering at least 2 mA and 12 V.

5.1.2 *Steel Cathode Test Pot*, as shown in Fig. 1.

5.1.3 *Copper Coulometer*, as shown in Fig. 2, or *Electronic Coulometer*.

5.1.4 *Saturated Calomel Reference Electrode*.

5.1.5 *Electrometer*, with an input impedance of  $10^7$  or greater ohms.

5.1.6 *Balance*, 100-g capacity with 0.1 mg sensitivity.

5.1.7 *Drying Oven*, with temperature capability of 110°C or higher.

### 6. Reagents

6.1 *Test Electrolyte, Saturated Calcium Sulfate-Magnesium Hydroxide Solution*—Add 5.0 g of reagent grade  $\text{CaSO}_4 \cdot 2\text{H}_2\text{O}$ ,

<sup>4</sup> Available from National Fire Protection Association, Inc., Batterymarch Park, Quincy, MA 02269.

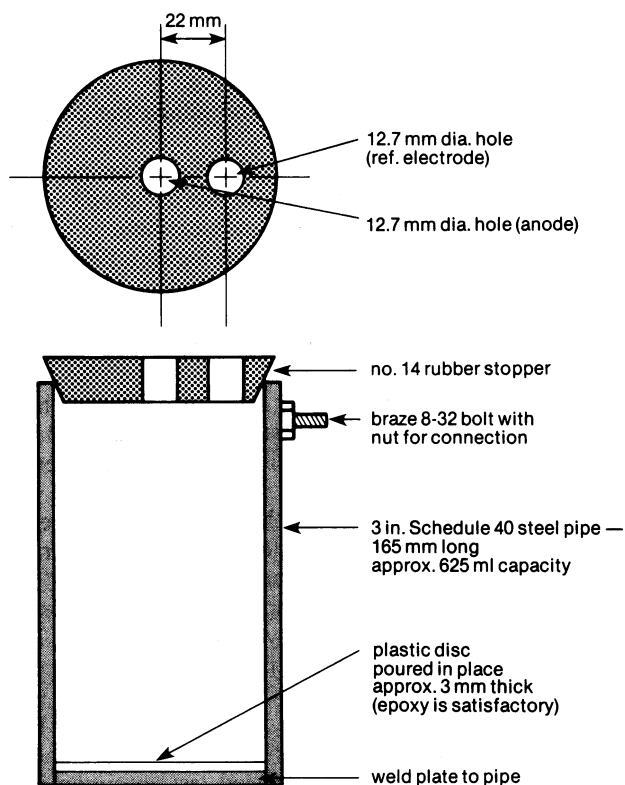

FIG. 1 Detail of Test Pot

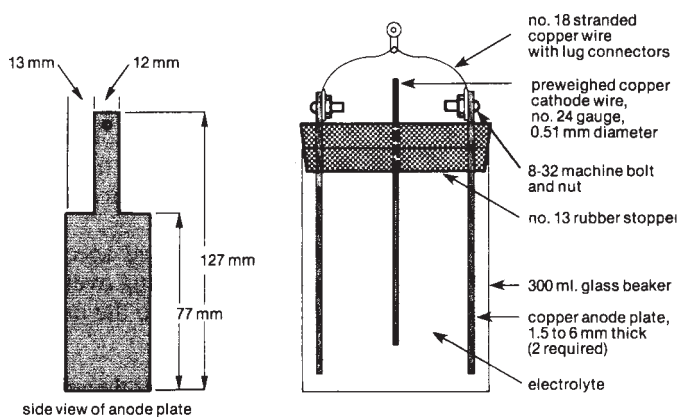

FIG. 2 Copper Coulometer

0.1 g of reagent grade  $Mg(OH)_2$ , to 1000 mL of Type IV or better reagent grade water (see Specification D 1193).

6.2 *Coulometer Solution*—Add 235 g of reagent grade  $CuSO_4 \cdot 5H_2O$ , 27 mL 98 %  $H_2SO_4$ , 50  $cm^3$  undenatured ethyl alcohol to 900 mL of Type IV or better reagent grade water.

6.3 *Anode Cleaning Solution*—Add 250 g of reagent grade  $CrO_3$  to 1000 mL of Type IV or better reagent grade water.

## 7. Precautions

7.1 Eye protection and skin protection are required when handling the coulometer solution and when handling the cleaning solution. Test specimen cleaning should be done in a ventilated laboratory hood.

7.2 Local, state, and federal regulations should be complied with in disposing of used cleaning solution.

## 8. Specimen Preparation

8.1 Fig. 3 shows typical test specimen selection and preparation from a cast anode. Since all sizes and shapes of cast anodes are not shown, the sampling is only illustrative. Test specimens are obtained across the width of a cast anode and approximately 13 mm from the edge. Machine each test specimen from a sawed, 180-mm long, 16-mm square cross section portion of the cast anode. Dry machine the square cross section, which should be marked with a stamped identification number, down to 12.7-mm diameter using a machining speed of 800 r/min, a feed rate of 0.5 mm per revolution, and a depth of cut of 1.9 mm or less. Cut the machined test specimen to a 152-mm length and machine-face one end.

8.1.1 Magnesium fines produced during cutting and machining operations can present a fire hazard. ANSI/NFPA 480 should be consulted for procedures for handling magnesium.

8.1.2 Band saws and power hacksaws with the following characteristics are recommended for use on magnesium:

8.1.2.1 *Blade pitch (teeth/cm)*—Band saw = 1.6 to 2.4, power hacksaw = 0.8 to 2.4.

8.1.2.2 *Tooth set (cm)*—Band saw = 0.05 to 0.13, power hacksaw = 0.038 to 0.076.

8.1.2.3 *End relief angle*—Band saw = 10 to 12°.

8.1.2.4 *Clearance angle*—Band saw = 20 to 30°, power hacksaw = 20 to 30°.

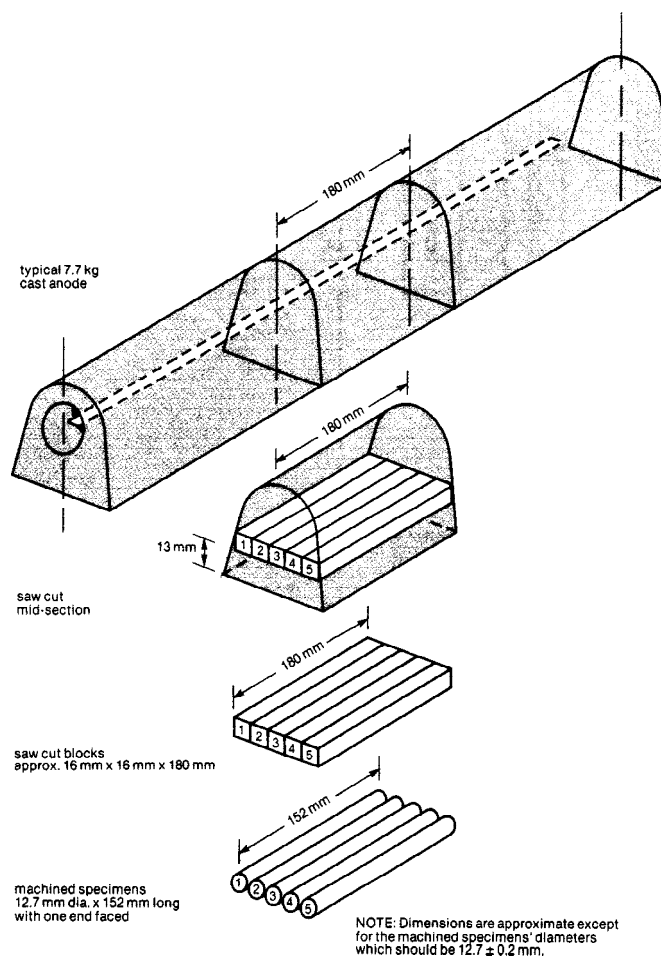

FIG. 3 Test Specimen Preparation from Cast Anode

8.2 Rinse each machined test specimen with water, rinse with acetone, dry in an oven at 105°C for 30 min, cool, and weigh to the nearest 0.1 mg. (**Warning**—The specimens should be handled with clean gloves at all times after the acetone rinsing step to avoid contamination of the specimens.)

8.3 Mask each weighed test specimen with electroplater's tape. Start 100 mm from the faced end and extend to approximately 13 mm from the non-faced end. The area exposed to the electrolyte will be the faced end, plus the side area for a length of 100 mm. This exposed area is 41.2 cm<sup>2</sup>. A current flow through the test circuit of 1.60 mA results in an anode current density of 0.039 mA/cm<sup>2</sup>.

8.4 Brush the test pots using a soft plastic brush. If the test pot internal surface becomes completely covered with a highly resistive coating that prevents the required current from being obtained, sandblast, wire brush, or scrape some of the hard adherent deposits off the surface.

8.5 If a copper coulometer rather than an electronic coulometer is used, prepare the copper coulometer as shown in Fig. 2. Buff the coulometer wire with fine (00 grit or finer) abrasive, dry in an oven at 105°C for 15 min, cool and weigh before assembling into the coulometer. The length of the copper wire in the coulometer solution should be between 10 and 50 mm. Clean the copper sheet anodes before their initial installation into the coulometer. The copper wire and sheet should have a purity of 99.9 % or higher.

8.6 Fig. 4 is a schematic diagram of the complete test circuit. Circuit wiring is No. 18 insulated stranded copper with alligator clips or lugs at each end of each wire. Use the calomel electrode only when oxidation potential measurements are being obtained.

## 9. Procedure (See Practice G 3)

9.1 Fill the cathode test pots to within approximately 15 mm of the top with the anode test electrolyte.

9.2 Insert the test specimens into the No. 14 rubber stoppers and insert the sample stopper assemblies into the cathode test pots.

9.3 Wire the circuit as shown in Fig. 4.

9.4 Turn on the power supply, adjust the current to 1.60 mA and check periodically to ensure the current remains constant at that level.

9.5 Obtain closed circuit test specimen potentials at 1, 7, and 14 days using a saturated calomel electrode and an electrometer. Obtain the potential measurement of each test specimen as shown in Fig. 4. The tip of the calomel reference should be within 10 mm of the test specimen surface when this measurement is made.

9.6 The electrolyte temperature should be 22 ± 5°C during the test.

9.7 Turn off the power supply after 14 days. One hour later open circuit potentials of the test specimens are obtained. The technique is identical to the closed circuit measurements (9.5).

9.8 Remove the wiring from the test specimens, remove the test specimens from the electrolyte and the rubber stoppers, and remove the tape from the specimens.

9.9 Place an untested test specimen in the cleaning solution which has been previously heated to 60–80°C. Leave the specimen in the solution for 10 min, rinse in tap water, and dry in an oven at 105°C for 30 min. If its mass loss is greater than 5 mg, discard the cleaning solution. If the untested test specimen mass loss is less than 5 mg, place the test specimens along with an untested test specimen in the 60–80°C cleaning solution for 10 min. Then rinse in tap water and dry in an oven at 105°C for 3 h. If the untested test specimen mass loss is greater than 5 mg, discard the cleaning solution and repeat the test.

9.9.1 An alternative cleaning procedure is to replace the 10 min immersion in 60–80°C cleaning solution with a 30 min immersion in ambient temperature cleaning solution.

9.10 If copper coulometers are used, remove the wires from the coulometer, rinse in tap water, and place in a drying oven at 105°C for 30 min.

9.11 Remove the test specimens, the untested specimen and the copper coulometer wires from the heating oven and allow to cool to room temperature, then weigh to the nearest 0.1 mg. (**Warning**—Clean gloves should be worn during the weighing process to avoid contamination of the specimens and coulometer wires.)

## 10. Calculation and Report (See Guide G 16)

10.1 Calculate and report the Ah passed through the test cells during the 14-day test.

10.1.1 If a copper coulometer is used, the Ah calculation is as follows:

$$Ah = (0.8433 \text{ Ah/g Cu}) (M_2 - M_1) \quad (1)$$

where:

$M_2$  = final mass of copper coulometer wire, g, and

$M_1$  = initial mass of copper coulometer wire, g.

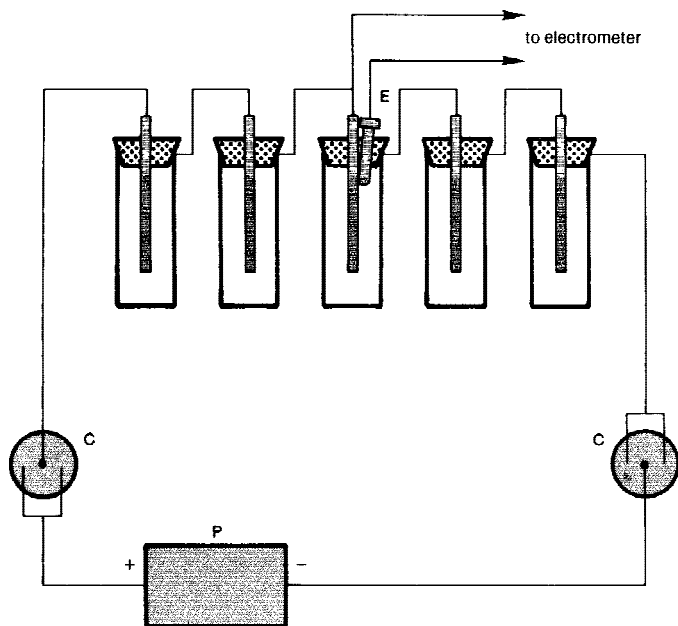

P = DC power supply  
C = Cu-CuSO<sub>4</sub> coulometer or electronic coulometer  
E = calomel electrode

FIG. 4 Experimental Cells

10.1.2 If an electronic coulometer is used, the Ah calculation is as follows:

$$Ah = (\text{ampere second measurement from coulometer}) / (3600) \quad (2)$$

10.2 Calculate and report the Ah per mass loss for each test specimen as follows:

$$Ah/g = (Ah) / (M_{Mg1} - M_{Mg2}) \quad (3)$$

where:

$M_{Mg1}$  = initial mass of magnesium test specimen, g, and

$M_{Mg2}$  = final mass of magnesium test specimen, g.

10.3 Report closed and open circuit potential measurements for each test specimen.

## 11. Precision and Bias <sup>5</sup>

11.1 The following criteria should be used to judge the acceptability of the results at the 5 % significance level.

11.1.1 *Repeatability*—Results (on identical test specimens) by the same operator should be considered suspect if the mean from five specimens differs by more than the following from the mean obtained from a duplicate test on five specimens.

Ah/g value	0.06 Ah/g
Final closed circuit potential	0.01 V

<sup>5</sup> The precision data were derived from results of cooperative tests on magnesium test samples. Supporting data available from ASTM headquarters. Request RR: G01-1007.

*ASTM International takes no position respecting the validity of any patent rights asserted in connection with any item mentioned in this standard. Users of this standard are expressly advised that determination of the validity of any such patent rights, and the risk of infringement of such rights, are entirely their own responsibility.*

*This standard is subject to revision at any time by the responsible technical committee and must be reviewed every five years and if not revised, either reapproved or withdrawn. Your comments are invited either for revision of this standard or for additional standards and should be addressed to ASTM International Headquarters. Your comments will receive careful consideration at a meeting of the responsible technical committee, which you may attend. If you feel that your comments have not received a fair hearing you should make your views known to the ASTM Committee on Standards, at the address shown below.*

*This standard is copyrighted by ASTM International, 100 Barr Harbor Drive, PO Box C700, West Conshohocken, PA 19428-2959, United States. Individual reprints (single or multiple copies) of this standard may be obtained by contacting ASTM at the above address or at 610-832-9585 (phone), 610-832-9555 (fax), or service@astm.org (e-mail); or through the ASTM website (www.astm.org).*

Open circuit potential	0.02 V
------------------------	--------

11.1.2 *Reproducibility*—Results (on identical test specimens) submitted by each of two laboratories should be considered suspect if the mean from five specimens tested by one lab differs by more than the following from the mean from five specimens tested by the other lab.

Ah/g value	0.15 Ah/g
Final closed circuit potential	0.05 V
Open circuit potential	0.08 V

11.1.3 Test specimens from the same casting may not be identical because of inhomogeneities in the casting. A method of insuring that identical test specimens are being evaluated is to retest a test specimen. The surface of the test specimen should be smoothed by machining before retesting. The new diameter should be measured and the test current adjusted so that the retest current density is 0.039 mA/cm<sup>2</sup>.

11.2 The values of potential and Ah per unit mass consumed as measured by this test method, may not agree with those found in field applications. It is unlikely that field results of Ah per unit mass consumed would ever be greater than those measured in this test. However, actual test comparisons are not sufficient to allow precise correlation of laboratory and field results.

## 12. Keywords

12.1 coulometer; electroplater's tape; sacrificial anode